

## HOW TO ORDER

XW-602A-□□-□□-L4-□

| code                              | Body color | code                              | Actuator color     | code                                | Actuator marking option | code                              | Mark color | code    | RoHS / non-RoHS |
|-----------------------------------|------------|-----------------------------------|--------------------|-------------------------------------|-------------------------|-----------------------------------|------------|---------|-----------------|
| B                                 | Black      | TR                                | Translucent red    | 00                                  |                         | 0                                 | no marking | no mark | non-RoHS        |
| G                                 | Grey       | TY                                | Translucent yellow | 02                                  |                         | B                                 | Black      | 7260    | RoHS            |
| W                                 | White      | TL                                | Translucent green  | 03                                  |                         | R                                 | Red        |         |                 |
| Other color options are available |            | Other color options are available |                    | 04                                  |                         | W                                 | White      |         |                 |
|                                   |            |                                   |                    | Other marking options are available |                         | Other color options are available |            |         |                 |

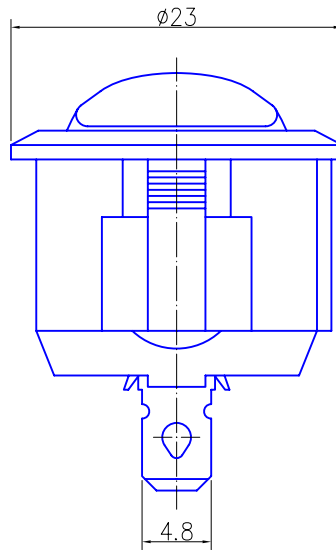

## SPECIFICATION

Rating: 6A 250VAC, 10A 125VAC, T85 – UL, cUL  
 10A 250VAC, T85/55 – ENEC18, TUV, CE  
 10A 125VAC – CQC

Contact Resistance: 50m ohm Max  
 Insulation Resistance: 1,000M OHM Min  
 Withstand Voltage: 1,000VAC 1minute  
 Life: 10,000 cycles  
 Switch Function: ON-OFF  
 Lamp Voltage: 250VAC  
 Material of rocker: PC, Translucent

|  |              |          |                            |                    |
|--|--------------|----------|----------------------------|--------------------|
|  | DWN: Z.L.Y.  |          | <b>DONGNAN ELECTRONICS</b> |                    |
|  | CHKD: W. Y.  | UNIT: mm | TITLE:                     | ROCKER SWITCH      |
|  | APVD: C.S.C. | SCALE:   | PART NO.:                  | XW-602A-□□-□□-L4-□ |