

- Low Supply-Voltage Range, 1.8 V . . . 3.6 V
- Ultralow-Power Consumption:
 - Active Mode: 280 μ A at 1 MHz, 2.2 V
 - Standby Mode: 1.6 μ A
 - Off Mode (RAM Retention): 0.1 μ A
- Five Power-Saving Modes
- Wake-Up From Standby Mode in 6 μ s
- 16-Bit RISC Architecture, 125-ns Instruction Cycle Time
- Three-Channel Internal DMA
- 12-Bit A/D Converter With Internal Reference, Sample-and-Hold and Autoscan Feature
- Dual 12-Bit D/A Converters With Synchronization
- 16-Bit Timer_A With Three Capture/Compare Registers
- 16-Bit Timer_B With Three or Seven Capture/Compare-With-Shadow Registers
- On-Chip Comparator
- Serial Communication Interface (USART1), Functions as Asynchronous UART or Synchronous SPI Interface
- Serial Communication Interface (USART0), Functions as Asynchronous UART or Synchronous SPI or I²C Interface
- Supply Voltage Supervisor/Monitor With Programmable Level Detection
- Brownout Detector
- Serial Onboard Programming, No External Programming Voltage Needed
- Programmable Code Protection by Security Fuse
- Bootstrap Loader
- Family Members Include:
 - MSP430F155:
 - 16KB+256B Flash Memory
 - 512B RAM
 - MSP430F156
 - 24KB+256B Flash Memory
 - 1KB RAM
 - MSP430F157:
 - 32KB+256B Flash Memory,
 - 1KB RAM
 - MSP430F167:
 - 32KB+256B Flash Memory,
 - 1KB RAM
 - MSP430F168:
 - 48KB+256B Flash Memory,
 - 2KB RAM
 - MSP430F169:
 - 60KB+256B Flash Memory,
 - 2KB RAM
 - MSP430F1610:
 - 32KB+256B Flash Memory
 - 5KB RAM
 - MSP430F1611
 - 48KB+256B Flash Memory
 - 10KB RAM
- Available in 64-Pin Quad Flat Pack (QFP)
- For Complete Module Descriptions, See the *MSP430x1xx Family User's Guide*, Literature Number SLAU049

PRODUCT PREVIEW

description

The Texas Instruments MSP430 family of ultralow power microcontrollers consist of several devices featuring different sets of peripherals targeted for various applications. The architecture, combined with five low power modes is optimized to achieve extended battery life in portable measurement applications. The device features a powerful 16-bit RISC CPU, 16-bit registers, and constant generators that attribute to maximum code efficiency. The digitally controlled oscillator (DCO) allows wake-up from low-power modes to active mode in less than 6 μ s.

The MSP430x15x/16x/161x series are microcontroller configurations with two built-in 16-bit timers, a fast 12-bit A/D converter, dual 12-bit D/A converter, one or two universal serial synchronous/asynchronous communication interfaces (USART), I²C, DMA, and 48 I/O pins. In addition, the MSP430x161x series offers extended RAM addressing for memory-intensive applications and large C-stack requirements.

Typical applications include sensor systems that capture analog signals, convert them to digital values, and process and transmit the data to a host system. The timers make the configurations ideal for industrial control applications such as digital motor control, hand-held meters, TEC control in optical networks, etc.



Please be aware that an important notice concerning availability, standard warranty, and use in critical applications of Texas Instruments semiconductor products and disclaimers thereto appears at the end of this data sheet.

PRODUCT PREVIEW information concerns products in the formative or design phase of development. Characteristic data and other specifications are design goals. Texas Instruments reserves the right to change or discontinue these products without notice.



POST OFFICE BOX 655303 • DALLAS, TEXAS 75265

Copyright © 2002 – 2003, Texas Instruments Incorporated

MSP430x15x, MSP430x16x, MSP430x161x MIXED SIGNAL MICROCONTROLLER

SLAS368A– OCTOBER 2002– REVISED MARCH 2003

AVAILABLE OPTIONS

T _A	PACKAGED DEVICES
	PLASTIC 64-PIN QFP (PM)
-40°C to 85°C	MSP430F155IPM MSP430F156IPM MSP430F157IPM MSP430F167IPM MSP430F168IPM MSP430F169IPM MSP430F1610IPM MSP430F1611IPM

pin designation, MSP430F155, MSP430F156, and MSP430F157

PM PACKAGE (TOP VIEW)

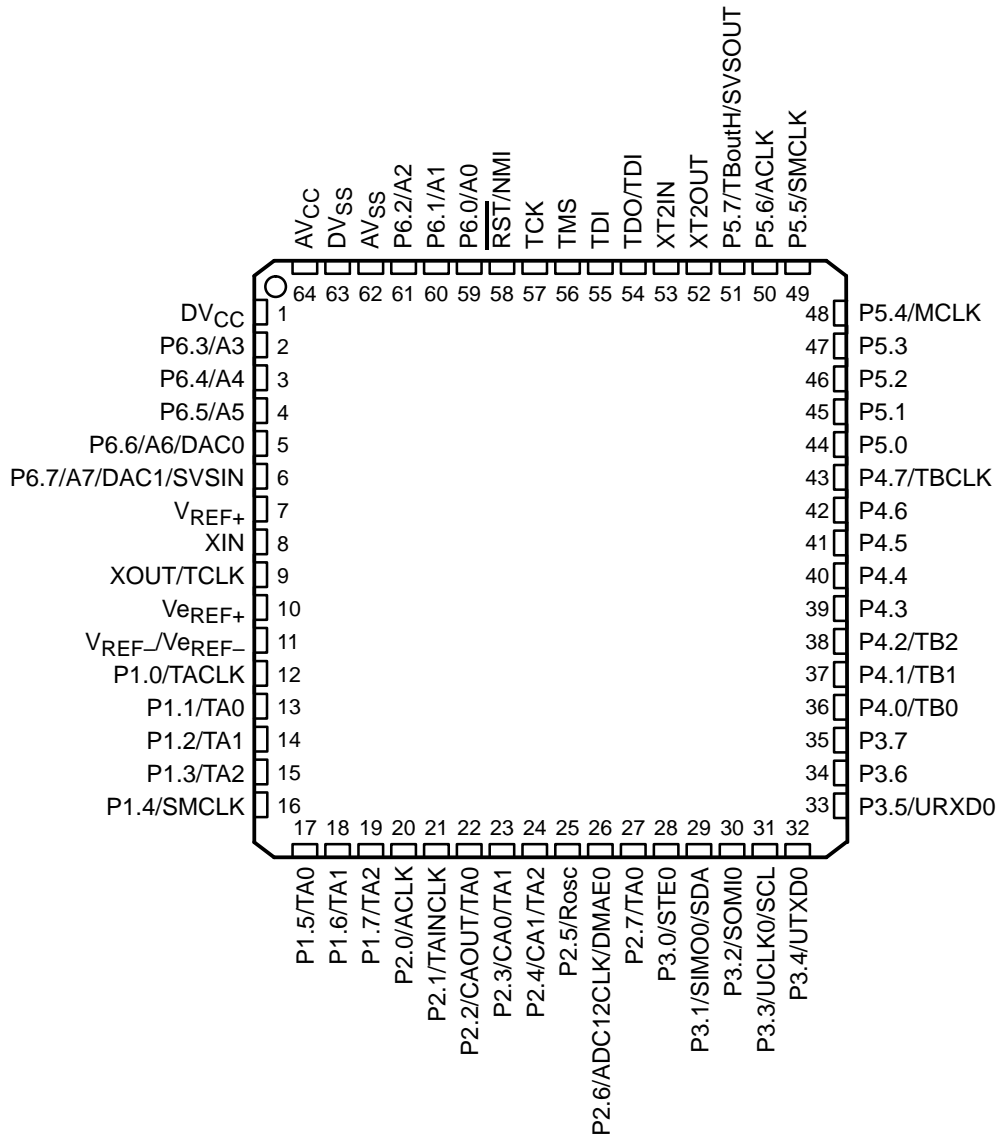

PRODUCT PREVIEW



POST OFFICE BOX 655303 • DALLAS, TEXAS 75265

MSP430x15x, MSP430x16x, MSP430x161x MIXED SIGNAL MICROCONTROLLER

SLAS368A– OCTOBER 2002– REVISED MARCH 2003

pin designation, MSP430F167, MSP430F168, MSP430F169

PM PACKAGE (TOP VIEW)

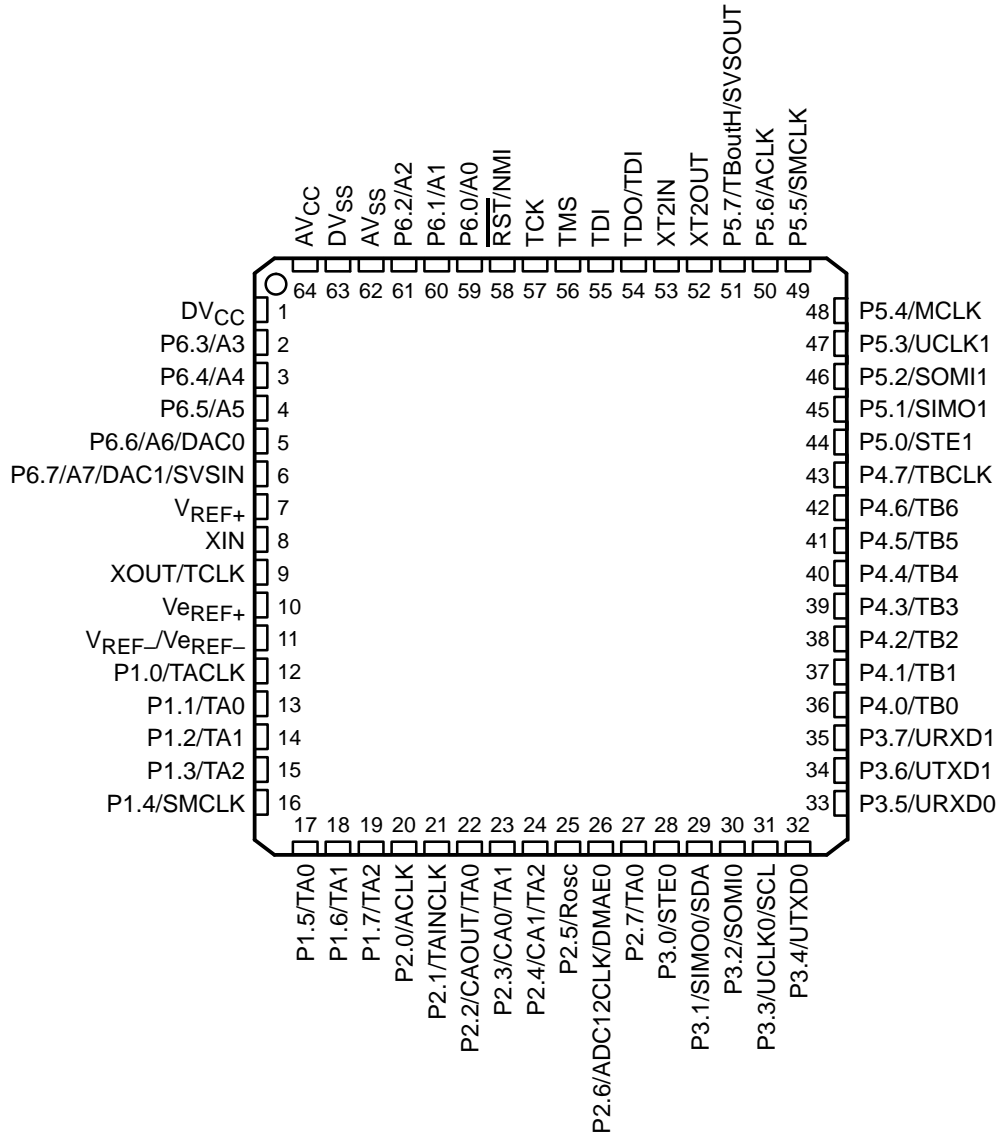

PRODUCT PREVIEW

MSP430x15x, MSP430x16x, MSP430x161x MIXED SIGNAL MICROCONTROLLER

SLAS368A– OCTOBER 2002– REVISED MARCH 2003

pin designation, MSP430F1610, MSP430F1611

PM PACKAGE
(TOP VIEW)

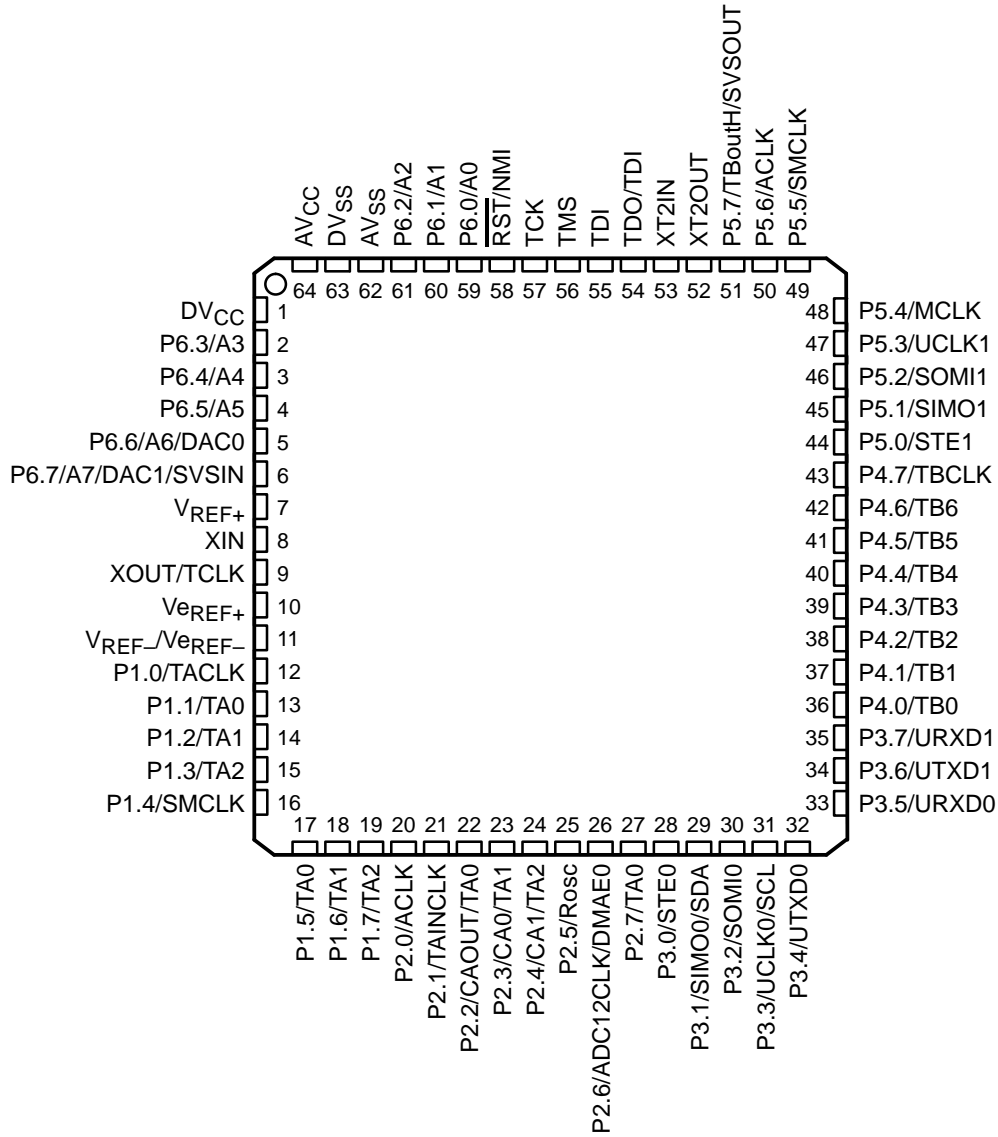

PRODUCT PREVIEW



POST OFFICE BOX 655303 • DALLAS, TEXAS 75265

MSP430x15x, MSP430x16x, MSP430x161x MIXED SIGNAL MICROCONTROLLER

SLAS368A—OCTOBER 2002—REVISED MARCH 2003

functional block diagrams

MSP430x15x

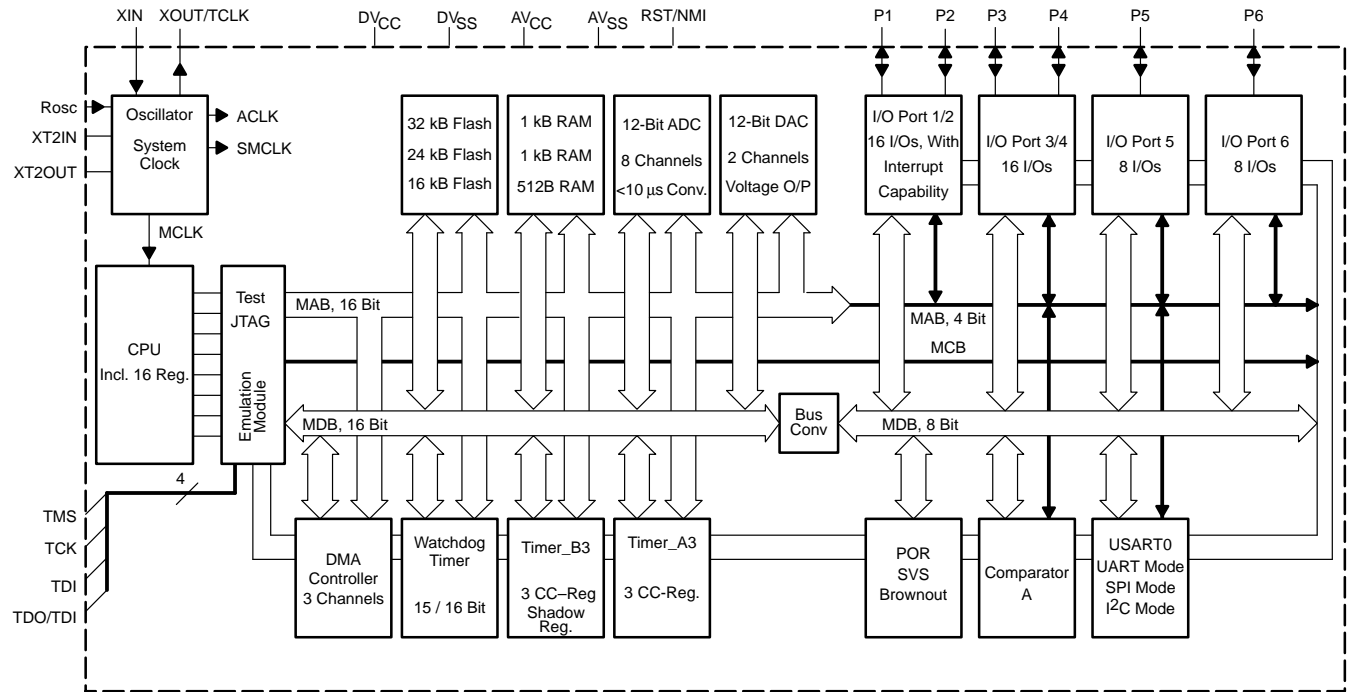

MSP430x16x

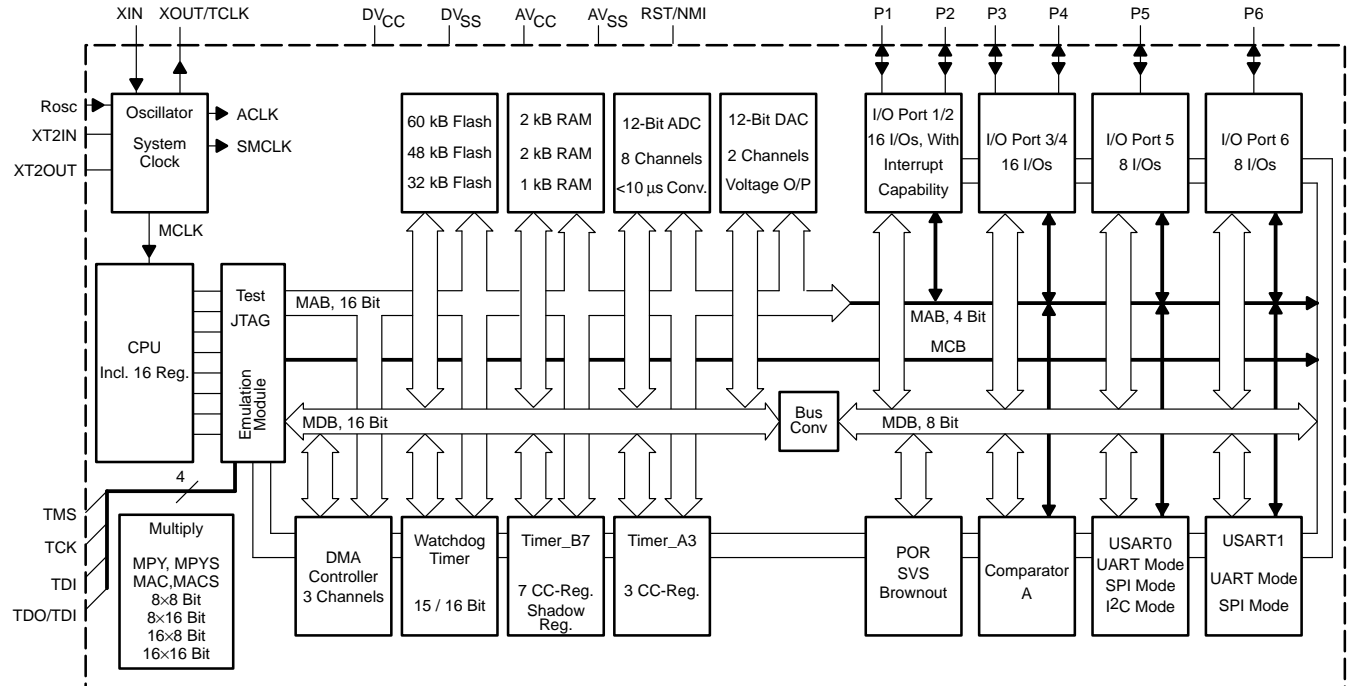

PRODUCT PREVIEW



MSP430x15x, MSP430x16x, MSP430x161x MIXED SIGNAL MICROCONTROLLER

SLAS368A– OCTOBER 2002– REVISED MARCH 2003

functional block diagrams

MSP430x161x

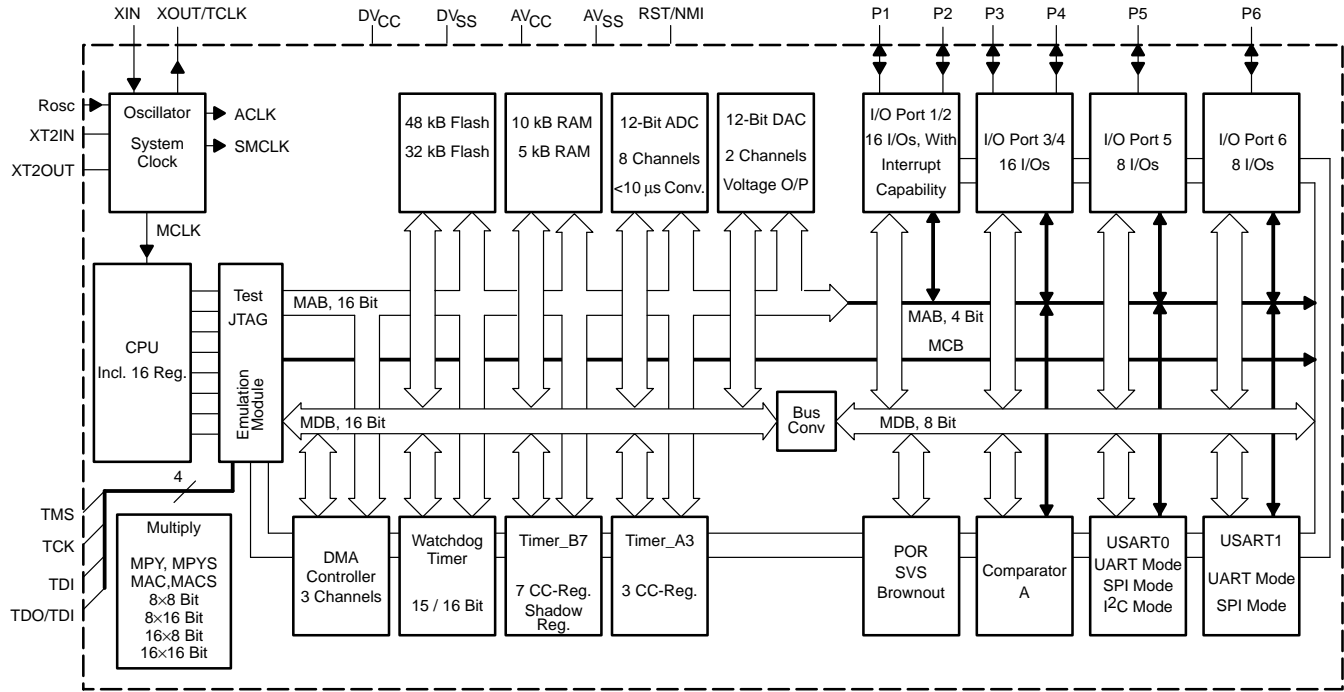

PRODUCT PREVIEW

Terminal Functions

TERMINAL NAME	NO.	I/O	DESCRIPTION
AV _{CC}	64		Analog supply voltage, positive terminal. Supplies only the analog portion of ADC12 and DAC12.
AV _{SS}	62		Analog supply voltage, negative terminal. Supplies only the analog portion of ADC12 and DAC12.
DV _{CC}	1		Digital supply voltage, positive terminal. Supplies all digital parts.
DV _{SS}	63		Digital supply voltage, negative terminal. Supplies all digital parts.
P1.0/TACLK	12	I/O	General-purpose digital I/O pin/Timer_A, clock signal TACLK input
P1.1/TA0	13	I/O	General-purpose digital I/O pin/Timer_A, capture: CCI0A input, compare: Out0 output
P1.2/TA1	14	I/O	General-purpose digital I/O pin/Timer_A, capture: CCI1A input, compare: Out1 output
P1.3/TA2	15	I/O	General-purpose digital I/O pin/Timer_A, capture: CCI2A input, compare: Out2 output
P1.4/SMCLK	16	I/O	General-purpose digital I/O pin/SMCLK signal output
P1.5/TA0	17	I/O	General-purpose digital I/O pin/Timer_A, compare: Out0 output
P1.6/TA1	18	I/O	General-purpose digital I/O pin/Timer_A, compare: Out1 output
P1.7/TA2	19	I/O	General-purpose digital I/O pin/Timer_A, compare: Out2 output/
P2.0/ACLK	20	I/O	General-purpose digital I/O pin/ACLK output
P2.1/TAINCLK	21	I/O	General-purpose digital I/O pin/Timer_A, clock signal at INCLK
P2.2/CAOUT/TA0	22	I/O	General-purpose digital I/O pin/Timer_A, capture: CCI0B input/Comparator_A output
P2.3/CA0/TA1	23	I/O	General-purpose digital I/O pin/Timer_A, compare: Out1 output/Comparator_A input
P2.4/CA1/TA2	24	I/O	General-purpose digital I/O pin/Timer_A, compare: Out2 output/Comparator_A input
P2.5/Rosc	25	I/O	General-purpose digital I/O pin, input for external resistor defining the DCO nominal frequency
P2.6/ADC12CLK/ DMAE0	26	I/O	General-purpose digital I/O pin, conversion clock – 12-bit ADC, DMA channel 0 external trigger
P2.7/TA0	27	I/O	General-purpose digital I/O pin/Timer_A, compare: Out0 output
P3.0/STE0	28	I/O	General-purpose digital I/O, slave transmit enable – USART0/SPI mode
P3.1/SIMO0/SDA	29	I/O	General-purpose digital I/O, slave in/master out of USART0/SPI mode, I ² C data – USART0/I ² C mode
P3.2/SOMI0	30	I/O	General-purpose digital I/O, slave out/master in of USART0/SPI mode
P3.3/UCLK0/SCL	31	I/O	General-purpose digital I/O, external clock input – USART0/UART or SPI mode, clock output – USART0/SPI mode, I ² C clock – USART0/I ² C mode
P3.4/UTXD0	32	I/O	General-purpose digital I/O, transmit data out – USART0/UART mode
P3.5/URXD0	33	I/O	General-purpose digital I/O, receive data in – USART0/UART mode
P3.6/UTXD1†	34	I/O	General-purpose digital I/O, transmit data out – USI1/UART mode
P3.7/URXD1†	35	I/O	General-purpose digital I/O, receive data in – USI1/UART mode
P4.0/TB0	36	I/O	General-purpose digital I/O, capture I/P or PWM output port – Timer_B7 CCR0
P4.1/TB1	37	I/O	General-purpose digital I/O, capture I/P or PWM output port – Timer_B7 CCR1
P4.2/TB2	38	I/O	General-purpose digital I/O, capture I/P or PWM output port – Timer_B7 CCR2
P4.3/TB3†	39	I/O	General-purpose digital I/O, capture I/P or PWM output port – Timer_B7 CCR3
P4.4/TB4†	40	I/O	General-purpose digital I/O, capture I/P or PWM output port – Timer_B7 CCR4
P4.5/TB5†	41	I/O	General-purpose digital I/O, capture I/P or PWM output port – Timer_B7 CCR5
P4.6/TB6†	42	I/O	General-purpose digital I/O, capture I/P or PWM output port – Timer_B7 CCR6
P4.7/TBCLK	43	I/O	General-purpose digital I/O, input clock TBCLK – Timer_B7
P5.0/STE1†	44	I/O	General-purpose digital I/O, slave transmit enable – USART1/SPI mode
P5.1/SIMO1†	45	I/O	General-purpose digital I/O slave in/master out of USART1/SPI mode
P5.2/SOMI1†	46	I/O	General-purpose digital I/O, slave out/master in of USART1/SPI mode
P5.3/UCLK1†	47	I/O	General-purpose digital I/O, external clock input – USART1/UART or SPI mode, clock output – USART1/SPI mode

† 16x, 161x devices only

PRODUCT PREVIEW

MSP430x15x, MSP430x16x, MSP430x161x MIXED SIGNAL MICROCONTROLLER

SLAS368A– OCTOBER 2002– REVISED MARCH 2003

Terminal Functions (Continued)

TERMINAL NAME	NO.	I/O	DESCRIPTION
P5.4/MCLK	48	I/O	General-purpose digital I/O, main system clock MCLK output
P5.5/SMCLK	49	I/O	General-purpose digital I/O, submain system clock SMCLK output
P5.6/ACLK	50	I/O	General-purpose digital I/O, auxiliary clock ACLK output
P5.7/TBouth/ SVSOUT	51	I/O	General-purpose digital I/O, switch all PWM digital output ports to high impedance – Timer_B7 TB0 to TB6, SVS comparator output
P6.0/A0	59	I/O	General-purpose digital I/O, analog input a0 – 12-bit ADC
P6.1/A1	60	I/O	General-purpose digital I/O, analog input a1 – 12-bit ADC
P6.2/A2	61	I/O	General-purpose digital I/O, analog input a2 – 12-bit ADC
P6.3/A3	2	I/O	General-purpose digital I/O, analog input a3 – 12-bit ADC
P6.4/A4	3	I/O	General-purpose digital I/O, analog input a4 – 12-bit ADC
P6.5/A5	4	I/O	General-purpose digital I/O, analog input a5 – 12-bit ADC
P6.6/A6/DAC0	5	I/O	General-purpose digital I/O, analog input a6 – 12-bit ADC, DAC12.0 output
P6.7/A7/DAC1/ SVSIN	6	I/O	General-purpose digital I/O, analog input a7 – 12-bit ADC, DAC12.1 output, SVS input
$\overline{\text{RST}}/\text{NMI}$	58	I	Reset input, nonmaskable interrupt input port, or bootstrap loader start (in Flash devices).
TCK	57	I	Test clock. TCK is the clock input port for device programming test and bootstrap loader start
TDI	55	I	Test data input. TDI is used as a data input port. The device protection fuse is connected to TDI.
TDO/TDI	54	I/O	Test data output port. TDO/TDI data output or programming data input terminal
TMS	56	I	Test mode select. TMS is used as an input port for device programming and test.
V _{REF+}	10	I/P	Input for an external reference voltage
V _{REF+}	7	O	Output of positive terminal of the reference voltage in the ADC12
V _{REF-} /V _{REF-}	11	O	Negative terminal for the reference voltage for both sources, the internal reference voltage, or an external applied reference voltage
XIN	8	I	Input port for crystal oscillator XT1. Standard or watch crystals can be connected.
XOUT/TCLK	9	I/O	Output terminal of crystal oscillator XT1 or test clock input
XT2IN	53	I	Input port for crystal oscillator XT2. Only standard crystals can be connected.
XT2OUT	52	O	Output terminal of crystal oscillator XT2

PRODUCT PREVIEW



short-form description

CPU

The MSP430 CPU has a 16-bit RISC architecture that is highly transparent to the application. All operations, other than program-flow instructions, are performed as register operations in conjunction with seven addressing modes for source operand and four addressing modes for destination operand.

The CPU is integrated with 16 registers that provide reduced instruction execution time. The register-to-register operation execution time is one cycle of the CPU clock.

Four of the registers, R0 to R3, are dedicated as program counter, stack pointer, status register, and constant generator respectively. The remaining registers are general-purpose registers.

Peripherals are connected to the CPU using data, address, and control buses, and can be handled with all instructions.

instruction set

The instruction set consists of 51 instructions with three formats and seven address modes. Each instruction can operate on word and byte data. Table 1 shows examples of the three types of instruction formats; the address modes are listed in Table 2.

Program Counter	PC/R0
Stack Pointer	SP/R1
Status Register	SR/CG1/R2
Constant Generator	CG2/R3
General-Purpose Register	R4
General-Purpose Register	R5
General-Purpose Register	R6
General-Purpose Register	R7
General-Purpose Register	R8
General-Purpose Register	R9
General-Purpose Register	R10
General-Purpose Register	R11
General-Purpose Register	R12
General-Purpose Register	R13
General-Purpose Register	R14
General-Purpose Register	R15

Table 1. Instruction Word Formats

Dual operands, source-destination	e.g. ADD R4,R5	R4 + R5 → R5
Single operands, destination only	e.g. CALL R8	PC →(TOS), R8→ PC
Relative jump, un/conditional	e.g. JNE	Jump-on-equal bit = 0

Table 2. Address Mode Descriptions

ADDRESS MODE	S	D	SYNTAX	EXAMPLE	OPERATION
Register	✓	✓	MOV Rs,Rd	MOV R10,R11	R10 → R11
Indexed	✓	✓	MOV X(Rn),Y(Rm)	MOV 2(R5),6(R6)	M(2+R5)→ M(6+R6)
Symbolic (PC relative)	✓	✓	MOV EDE,TONI		M(EDE) → M(TONI)
Absolute	✓	✓	MOV and MEM,and TCDAT		M(MEM) → M(TCDAT)
Indirect	✓		MOV @Rn,Y(Rm)	MOV @R10,Tab(R6)	M(R10) → M(Tab+R6)
Indirect autoincrement	✓		MOV @Rn+,Rm	MOV @R10+,R11	M(R10) → R11 R10 + 2 → R10
Immediate	✓		MOV #X,TONI	MOV #45,TONI	#45 → M(TONI)

NOTE: S = source D = destination

MSP430x15x, MSP430x16x, MSP430x161x MIXED SIGNAL MICROCONTROLLER

SLAS368A– OCTOBER 2002– REVISED MARCH 2003

operating modes

The MSP430 has one active mode and five software selectable low-power modes of operation. An interrupt event can wake up the device from any of the five low-power modes, service the request and restore back to the low-power mode on return from the interrupt program.

The following six operating modes can be configured by software:

- Active mode AM;
 - All clocks are active
- Low-power mode 0 (LPM0);
 - CPU is disabled
ACLK and SMCLK remain active. MCLK is disabled
- Low-power mode 1 (LPM1);
 - CPU is disabled
ACLK and SMCLK remain active. MCLK is disabled
DCO's dc-generator is disabled if DCO not used in active mode
- Low-power mode 2 (LPM2);
 - CPU is disabled
MCLK and SMCLK are disabled
DCO's dc-generator remains enabled
ACLK remains active
- Low-power mode 3 (LPM3);
 - CPU is disabled
MCLK and SMCLK are disabled
DCO's dc-generator is disabled
ACLK remains active
- Low-power mode 4 (LPM4);
 - CPU is disabled
ACLK is disabled
MCLK and SMCLK are disabled
DCO's dc-generator is disabled
Crystal oscillator is stopped

PRODUCT PREVIEW



interrupt vector addresses

The interrupt vectors and the power-up starting address are located in the address range 0FFFFh – 0FFE0h. The vector contains the 16-bit address of the appropriate interrupt-handler instruction sequence.

INTERRUPT SOURCE	INTERRUPT FLAG	SYSTEM INTERRUPT	WORD ADDRESS	PRIORITY
Power-up External Reset Watchdog Flash memory	WDTIFG KEYV (see Note 1)	Reset	0FFFEh	15, highest
NMI Oscillator Fault Flash memory access violation	NMIIFG (see Notes 1 & 3) OFIFG (see Notes 1 & 3) ACCVIFG (see Notes 1 & 3)	(Non)maskable (Non)maskable (Non)maskable	0FFFCh	14
Timer_B7 (see Note 5)	TBCCR0 CCIFG (see Note 2)	Maskable	0FFFAh	13
Timer_B7 (see Note 5)	TBCCR1 to TBCCR6 CCIFGs, TBIFG (see Notes 1 & 2)	Maskable	0FFF8h	12
Comparator_A	CAIFG	Maskable	0FFF6h	11
Watchdog timer	WDTIFG	Maskable	0FFF4h	10
USART0 receive I ² C transmit/receive/others	URXIFG0, I2CIFG (see Note 4)	Maskable	0FFF2h	9
USART0 transmit	UTXIFG0	Maskable	0FFF0h	8
ADC12	ADC12IFG (see Notes 1 & 2)	Maskable	0FFEEh	7
Timer_A3	TACCR0 CCIFG (see Note 2)	Maskable	0FFECh	6
Timer_A3	TACCR1 and TACCR2 CCIFGs, TAIFG (see Notes 1 & 2)	Maskable	0FFEAh	5
I/O port P1 (eight flags)	P1IFG.0 (see Notes 1 & 2) To P1IFG.7 (see Notes 1 & 2)	Maskable	0FFE8h	4
USART1 receive	URXIFG1	Maskable	0FFE6h	3
USART1 transmit	UTXIFG1	Maskable	0FFE4h	2
I/O port P2 (eight flags)	P2IFG.0 (see Notes 1 & 2) To P2IFG.7 (see Notes 1 & 2)	Maskable	0FFE2h	1
DAC12 DMA	DAC12_0IFG, DAC12_1IFG, DMA0IFG, DMA1IFG, DMA2IFG (see Notes 1 & 2)	Maskable	0FFE0h	0, lowest

- NOTES: 1. Multiple source flags
 2. Interrupt flags are located in the module.
 3. (Non)maskable: the individual interrupt-enable bit can disable an interrupt event, but the general-interrupt enable cannot disable it.
 4. I²C interrupt flags located in the module
 5. Timer_B7 in MSP430x16x/161x family has 7 CCRs; Timer_B3 in MSP430x15x family has 3 CCRs; in Timer_B3 there are only interrupt flags TBCCR0, 1 and 2 CCIFGs and the interrupt-enable bits TBCCR0, 1 and 2 CCIEs.

MSP430x15x, MSP430x16x, MSP430x161x MIXED SIGNAL MICROCONTROLLER

SLAS368A– OCTOBER 2002– REVISED MARCH 2003

special function registers

Most interrupt and module-enable bits are collected in the lowest address space. Special-function register bits not allocated to a functional purpose are not physically present in the device. This arrangement provides simple software access.

interrupt enable 1 and 2

Address	7	6	5	4	3	2	1	0
0h	UTXIE0	URXIE0	ACCVIE	NMIIE			OFIE	WDTIE
	rw-0	rw-0	rw-0	rw-0			rw-0	rw-0

WDTIE: Watchdog timer interrupt enable. Inactive if watchdog mode is selected. Active if watchdog timer is configured as general-purpose timer.

OFIE: Oscillator-fault-interrupt enable

NMIIE: Nonmaskable-interrupt enable

ACCVIE: Flash memory access violation interrupt enable

URXIE0: USART0, UART, and SPI receive-interrupt enable

UTXIE0: USART0, UART, and SPI transmit-interrupt enable

Address	7	6	5	4	3	2	1	0
01h			UTXIE1	URXIE1				
			rw-0	rw-0				

URXIE1†: USART1, UART, and SPI receive-interrupt enable

UTXIE1†: USART1, UART, and SPI transmit-interrupt enable

† URXIE1 and UTXIE1 are not present in MSP430x15x devices.

interrupt flag register 1 and 2

Address	7	6	5	4	3	2	1	0
02h	UTXIFG0	URXIFG0		NMIIFG			OFIFG	WDTIFG
	rw-1	rw-0		rw-0			rw-1	rw-0

WDTIFG: Set on watchdog-timer overflow (in watchdog mode) or security key violation
Reset on V_{CC} power-on, or a reset condition at the \overline{RST}/NMI pin in reset mode

OFIFG: Flag set on oscillator fault

NMIIFG: Set via \overline{RST}/NMI pin

URXIFG0: USART0, UART, and SPI receive flag

UTXIFG0: USART0, UART, and SPI transmit flag

Address	7	6	5	4	3	2	1	0
03h			UTXIFG1	URXIFG1				
			rw-1	rw-0				

URXIFG1‡: USART1, UART, and SPI receive flag

UTXIFG1‡: USART1, UART, and SPI transmit flag

‡ URXIFG1 and UTXIFG1 are not present in MSP430x15x devices.

module enable registers 1 and 2

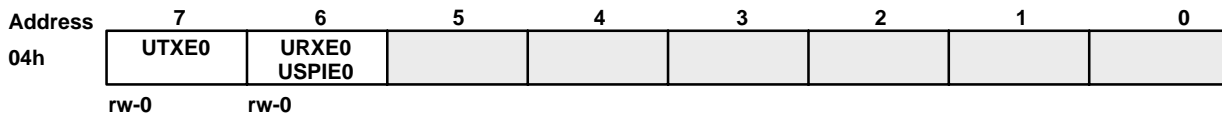

- URXE0: USART0, UART mode receive enable
- UTXE0: USART0, UART mode transmit enable
- USPIE0: USART0, SPI mode transmit and receive enable

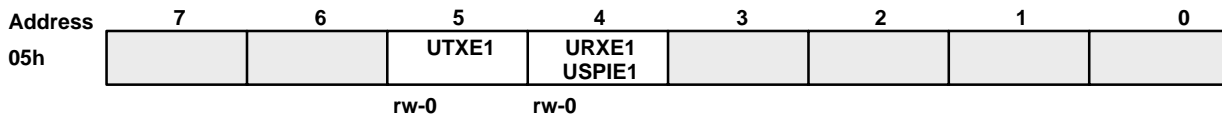

- URXE1†: USART1, UART mode receive enable
- UTXE1†: USART1, UART mode transmit enable
- USPIE1†: USART1, SPI mode transmit and receive enable

† URXE1, UTXE1, and USPIE1 are not present in MSP430x15x devices.

Legend: rw: Bit Can Be Read and Written
 rw-0: Bit Can Be Read and Written. It Is Reset by PUC.
 SFR Bit Not Present in Device

PRODUCT PREVIEW

MSP430x15x, MSP430x16x, MSP430x161x MIXED SIGNAL MICROCONTROLLER

SLAS368A– OCTOBER 2002– REVISED MARCH 2003

memory organization (MSP430F15x)

		MSP430F155	MSP430F156	MSP430F157
Memory	Size	16kB	24kB	32kB
Main: interrupt vector	Flash	0FFFFh – 0FFE0h	0FFFFh – 0FFE0h	0FFFFh – 0FFE0h
Main: code memory	Flash	0FFFFh – 0C000h	0FFFFh – 0A000h	0FFFFh – 08000h
Information memory	Size	256 Byte	256 Byte	256 Byte
	Flash	010FFh – 01000h	010FFh – 01000h	010FFh – 01000h
Boot memory	Size	1kB	1kB	1kB
	ROM	0FFFh – 0C00h	0FFFh – 0C00h	0FFFh – 0C00h
RAM	Size	512B	1kB	1kB
		03FFh – 0200h	05FFh – 0200h	05FFh – 0200h
Peripherals	16-bit	01FFh – 0100h	01FFh – 0100h	01FFh – 0100h
	8-bit	0FFh – 010h	0FFh – 010h	0FFh – 010h
	8-bit SFR	0Fh – 00h	0Fh – 00h	0Fh – 00h

memory organization (MSP430F16x)

		MSP430F167	MSP430F168	MSP430F169
Memory	Size	32kB	48kB	60kB
Main: interrupt vector	Flash	0FFFFh – 0FFE0h	0FFFFh – 0FFE0h	0FFFFh – 0FFE0h
Main: code memory	Flash	0FFFFh – 08000h	0FFFFh – 04000h	0FFFFh – 01100h
Information memory	Size	256 Byte	256 Byte	256 Byte
	Flash	010FFh – 01000h	010FFh – 01000h	010FFh – 01000h
Boot memory	Size	1kB	1kB	1kB
	ROM	0FFFh – 0C00h	0FFFh – 0C00h	0FFFh – 0C00h
RAM	Size	1kB	2kB	2kB
		05FFh – 0200h	09FFh – 0200h	09FFh – 0200h
Peripherals	16-bit	01FFh – 0100h	01FFh – 0100h	01FFh – 0100h
	8-bit	0FFh – 010h	0FFh – 010h	0FFh – 010h
	8-bit SFR	0Fh – 00h	0Fh – 00h	0Fh – 00h

memory organization (MSP430F161x)

		MSP430F1610	MSP430F1611
Memory	Size	32kB	48kB
Main: interrupt vector	Flash	0FFFFh – 0FFE0h	0FFFFh – 0FFE0h
Main: code memory	Flash	0FFFFh – 08000h	0FFFFh – 04000h
RAM	Size	3kB	8kB
		024FFh – 01100h	038FFh – 01100h
Information memory	Size	256 Byte	256 Byte
	Flash	010FFh – 01000h	010FFh – 01000h
Boot memory	Size	1kB	1kB
	ROM	0FFFh – 0C00h	0FFFh – 0C00h
RAM	Size	2kB	2kB
		09FFh – 0200h	09FFh – 0200h
Peripherals	16-bit	01FFh – 0100h	01FFh – 0100h
	8-bit	0FFh – 010h	0FFh – 010h
	8-bit SFR	0Fh – 00h	0Fh – 00h

PRODUCT PREVIEW



bootstrap loader (BSL)

The MSP430 bootstrap loader (BSL) enables users to program the flash memory or RAM using a UART serial interface. Access to the MSP430 memory via the BSL is protected by user-defined password. For complete description of the features of the BSL and its implementation, see the Application report *Features of the MSP430 Bootstrap Loader*, Literature Number SLAA089.

flash memory

The flash memory can be programmed via the JTAG port, the bootstrap loader, or in-system by the CPU. The CPU can perform single-byte and single-word writes to the flash memory. Features of the flash memory include:

- Flash memory has n segments of main memory and two segments of information memory (A and B) of 128 bytes each. Each segment in main memory is 512 bytes in size.
- Segments 0 to n may be erased in one step, or each segment may be individually erased.
- Segments A and B can be erased individually, or as a group with segments 0–n. Segments A and B are also called *information memory*.
- New devices may have some bytes programmed in the information memory (needed for test during manufacturing). The user should perform an erase of the information memory prior to the first use.

MSP430F15x and MSP430F161x					MSP430F161x		
16KB	24KB	32KB	48KB	60KB	32KB	48KB	
0FFFFh	0FFFFh	0FFFFh	0FFFFh	0FFFFh	0FFFFh	0FFFFh	Segment 0 w/ Interrupt Vectors
0FE00h	0FE00h	0FE00h	0FE00h	0FE00h	0FE00h	0FE00h	Segment 1
0FDFFh	0FDFFh	0FDFFh	0FDFFh	0FDFFh	0FDFFh	0FDFFh	Segment 2
0FC00h	0FC00h	0FC00h	0FC00h	0FC00h	0FC00h	0FC00h	⋮
0FBFFh	0FBFFh	0FBFFh	0FBFFh	0FBFFh	0FBFFh	0FBFFh	
0FA00h	0FA00h	0FA00h	0FA00h	0FA00h	0FA00h	0FA00h	⋮
0F9FFh	0F9FFh	0F9FFh	0F9FFh	0F9FFh	0F9FFh	0F9FFh	
0C400h	0A400h	08400h	04400h	01400h	08400h	04400h	⋮
0C3FFh	0A3FFh	083FFh	043FFh	013FFh	083FFh	043FFh	
0C200h	0A200h	08200h	04200h	01200h	08200h	04200h	⋮
0C1FFh	0A1FFh	081FFh	041FFh	011FFh	081FFh	041FFh	
0C000h	0A000h	08000h	04000h	01100h	08000h	04000h	⋮
					024FFh	038FFh	
010FFh	010FFh	010FFh	010FFh	010FFh	01100h	01100h	⋮
					010FFh	010FFh	
01080h	01080h	01080h	01080h	01080h	01080h	01080h	⋮
0107Fh	0107Fh	0107Fh	0107Fh	0107Fh	0107Fh	0107Fh	
01000h	01000h	01000h	01000h	01000h	01000h	01000h	Segment A
							Segment B

Main Memory

RAM
(F161x only)

Information Memory

MSP430x15x, MSP430x16x, MSP430x161x MIXED SIGNAL MICROCONTROLLER

SLAS368A– OCTOBER 2002– REVISED MARCH 2003

peripherals

Peripherals are connected to the CPU through data, address, and control busses and can be handled using all instructions.

DMA controller

The DMA controller allows movement of data from one memory address to another without CPU intervention. For example, the DMA controller can be used to move data from the ADC12 conversion memory to RAM. Using the DMA controller can increase the throughput of peripheral modules. The DMA controller reduces system power consumption by allowing the CPU to remain in sleep mode without having to awaken to move data to or from a peripheral.

oscillator and system clock

The clock system in the MSP430x15x and MSP430x16x(x) family of devices is supported by the basic clock module that includes support for a 32768-Hz watch crystal oscillator, an internal digitally-controlled oscillator (DCO) and a high frequency crystal oscillator. The basic clock module is designed to meet the requirements of both low system cost and low-power consumption. The internal DCO provides a fast turn-on clock source and stabilizes in less than 6 μ s. The basic clock module provides the following clock signals:

- Auxiliary clock (ACLK), sourced from a 32768-Hz watch crystal or a high frequency crystal.
- Main clock (MCLK), the system clock used by the CPU.
- Sub-Main clock (SMCLK), the sub-system clock used by the peripheral modules.

brownout, supply voltage supervisor

The brownout circuit is implemented to provide the proper internal reset signal to the device during power on and power off. The supply voltage supervisor (SVS) circuitry detects if the supply voltage drops below a user selectable level and supports both supply voltage supervision (the device is automatically reset) and supply voltage monitoring (SVM, the device is not automatically reset).

The CPU begins code execution after the brownout circuit releases the device reset. However, V_{CC} may not have ramped to $V_{CC(min)}$ at that time. The user must insure the default FLL+ settings are not changed until V_{CC} reaches $V_{CC(min)}$. If desired, the SVS circuit can be used to determine when V_{CC} reaches $V_{CC(min)}$.

digital I/O

There are six 8-bit I/O ports implemented—ports P1 through P6:

- All individual I/O bits are independently programmable.
- Any combination of input, output, and interrupt conditions is possible.
- Edge-selectable interrupt input capability for all the eight bits of ports P1 and P2.
- Read/write access to port-control registers is supported by all instructions.

watchdog timer

The primary function of the watchdog timer (WDT) module is to perform a controlled system restart after a software problem occurs. If the selected time interval expires, a system reset is generated. If the watchdog function is not needed in an application, the module can be configured as an interval timer and can generate interrupts at selected time intervals.

multiplication (MSP430x16x/161x Only)

The multiplication operation is supported by a dedicated peripheral module. The module performs 16×16 , 16×8 , 8×16 , and 8×8 bit operations. The module is capable of supporting signed and unsigned multiplication as well as signed and unsigned multiply and accumulate operations. The result of an operation can be accessed immediately after the operands have been loaded into the peripheral registers. No additional clock cycles are required.

USART0

The MSP430x15x and the MSP430x16x(x) have one hardware universal synchronous/asynchronous receive transmit (USART0) peripheral module that is used for serial data communication. The USART supports synchronous SPI (3 or 4 pin), asynchronous UART and I2C communication protocols using double-buffered transmit and receive channels.

The I²C support is compliant with the Phillips I²C specification version 2.1 and supports standard mode (up to 100 kbps) and fast mode (up to 400 kbps). In addition, 7-bit and 10-bit device addressing modes are supported, as well as master and slave modes. The USART0 also supports 16-bit-wide I²C data transfers and has two dedicated DMA channels to maximize bus throughput. Extensive interrupt capability is also given in the I²C mode.

USART1 (MSP430x16x/161x Only)

The MSP430x16x(x) devices have a second hardware universal synchronous/asynchronous receive transmit (USART1) peripheral module that is used for serial data communication. The USART supports synchronous SPI (3 or 4 pin) and asynchronous UART communication protocols, using double-buffered transmit and receive channels. With the exception of I2C support, operation of USART1 is identical to USART0.

timer_A3

Timer_A3 is a 16-bit timer/counter with three capture/compare registers. Timer_A3 can support multiple capture/compares, PWM outputs, and interval timing. Timer_A3 also has extensive interrupt capabilities. Interrupts may be generated from the counter on overflow conditions and from each of the capture/compare registers.

timer_B7 (MSP430x16x/161x Only)

Timer_B7 is a 16-bit timer/counter with seven capture/compare registers. Timer_B7 can support multiple capture/compares, PWM outputs, and interval timing. Timer_B7 also has extensive interrupt capabilities. Interrupts may be generated from the counter on overflow conditions and from each capture/compare register.

timer_B3 (MSP430x15x Only)

Timer_B3 is a 16-bit timer/counter with three capture/compare registers. Timer_B3 can support multiple capture/compares, PWM outputs, and interval timing. Timer_B3 also has extensive interrupt capabilities. Interrupts may be generated from the counter on overflow conditions and from each capture/compare register.

comparator_A

The primary function of the comparator_A module is to support precision slope analog-to-digital conversions, battery-voltage supervision, and monitoring of external analog signals.

ADC12

The ADC12 module supports fast, 12-bit analog-to-digital conversions. The module implements a 12-bit SAR core, sample select control, reference generator and a 16 word conversion-and-control buffer. The conversion-and-control buffer allows up to 16 independent ADC samples to be converted and stored without any CPU intervention.

DAC12

The DAC12 module is a 12-bit, R-ladder, voltage output DAC. The DAC12 may be used in 8- or 12-bit mode, and may be used in conjunction with the DMA controller. When multiple DAC12 modules are present, they may be grouped together for synchronous operation.

MSP430x15x, MSP430x16x, MSP430x161x MIXED SIGNAL MICROCONTROLLER

SLAS368A– OCTOBER 2002– REVISED MARCH 2003

peripheral file map

PERIPHERAL FILE MAP			
DMA	DMA channel 2 transfer size	DMA2SZ	01F6h
	DMA channel 2 destination address	DMA2DA	01F4h
	DMA channel 2 source address	DMA2SA	01F2h
	DMA channel 2 control	DMA2CTL	01F0h
	DMA channel 1 transfer size	DMA1SZ	01EEh
	DMA channel 1 destination address	DMA1DA	01ECh
	DMA channel 1 source address	DMA1SA	01EAh
	DMA channel 1 control	DMA1CTL	01E8h
	DMA channel 0 transfer size	DMA0SZ	01E6h
	DMA channel 0 destination address	DMA0DA	01E4h
	DMA channel 0 source address	DMA0SA	01E2h
	DMA channel 0 control	DMA0CTL	01E0h
	DMA module control 1	DMACTL1	0124h
	DMA module control 0	DMACTL0	0122h
DAC12	DAC12_1 data	DAC12_1DAT	01CAh
	DAC12_1 control	DAC12_1CTL	01C2h
	DAC12_0 data	DAC12_0DAT	01C8h
	DAC12_0 control	DAC12_0CTL	01C0h
ADC12	Interrupt-vector-word register	ADC12IV	01A8h
	Interrupt-enable register	ADC12IE	01A6h
	Interrupt-flag register	ADC12IFG	01A4h
	Control register 1	ADC12CTL1	01A2h
	Control register 0	ADC12CTL0	01A0h
	Conversion memory 15	ADC12MEM15	015Eh
	Conversion memory 14	ADC12MEM14	015Ch
	Conversion memory 13	ADC12MEM13	015Ah
	Conversion memory 12	ADC12MEM12	0158h
	Conversion memory 11	ADC12MEM11	0156h
	Conversion memory 10	ADC12MEM10	0154h
	Conversion memory 9	ADC12MEM9	0152h
	Conversion memory 8	ADC12MEM8	0150h
	Conversion memory 7	ADC12MEM7	014Eh
	Conversion memory 6	ADC12MEM6	014Ch
	Conversion memory 5	ADC12MEM5	014Ah
	Conversion memory 4	ADC12MEM4	0148h
	Conversion memory 3	ADC12MEM3	0146h
	Conversion memory 2	ADC12MEM2	0144h
	Conversion memory 1	ADC12MEM1	0142h
Conversion memory 0	ADC12MEM0	0140h	

PRODUCT PREVIEW



peripheral file map (continued)

PERIPHERAL FILE MAP (CONTINUED)			
ADC12 (continued)	ADC memory-control register15	ADC12MCTL15	08Fh
	ADC memory-control register14	ADC12MCTL14	08Eh
	ADC memory-control register13	ADC12MCTL13	08Dh
	ADC memory-control register12	ADC12MCTL12	08Ch
	ADC memory-control register11	ADC12MCTL11	08Bh
	ADC memory-control register10	ADC12MCTL10	08Ah
	ADC memory-control register9	ADC12MCTL9	089h
	ADC memory-control register8	ADC12MCTL8	088h
	ADC memory-control register7	ADC12MCTL7	087h
	ADC memory-control register6	ADC12MCTL6	086h
	ADC memory-control register5	ADC12MCTL5	085h
	ADC memory-control register4	ADC12MCTL4	084h
	ADC memory-control register3	ADC12MCTL3	083h
	ADC memory-control register2	ADC12MCTL2	082h
	ADC memory-control register1	ADC12MCTL1	081h
	ADC memory-control register0	ADC12MCTL0	080h
	Timer_B7/ Timer_B3 (see Note 6)	Capture/compare register 6	TBCCR6
Capture/compare register 5		TBCCR5	019Ch
Capture/compare register 4		TBCCR4	019Ah
Capture/compare register 3		TBCCR3	0198h
Capture/compare register 2		TBCCR2	0196h
Capture/compare register 1		TBCCR1	0194h
Capture/compare register 0		TBCCR0	0192h
Timer_B register		TBR	0190h
Capture/compare control 6		TBCCTL6	018Eh
Capture/compare control 5		TBCCTL5	018Ch
Capture/compare control 4		TBCCTL4	018Ah
Capture/compare control 3		TBCCTL3	0188h
Capture/compare control 2		TBCCTL2	0186h
Capture/compare control 1		TBCCTL1	0184h
Capture/compare control 0		TBCCTL0	0182h
Timer_B control		TBCTL	0180h
Timer_B interrupt vector		TBIV	011Eh
Timer_A3	Reserved		017Eh
	Reserved		017Ch
	Reserved		017Ah
	Reserved		0178h
	Capture/compare register 2	TACCR2	0176h
	Capture/compare register 1	TACCR1	0174h
	Capture/compare register 0	TACCR0	0172h
	Timer_A register	TAR	0170h
	Reserved		016Eh
	Reserved		016Ch
	Reserved		016Ah
	Reserved		0168h

NOTE 6: Timer_B7 in MSP430x16x/161x family has 7 CCR, Timer_B3 in MSP430x15x family has 3 CCR.

MSP430x15x, MSP430x16x, MSP430x161x MIXED SIGNAL MICROCONTROLLER

SLAS368A– OCTOBER 2002– REVISED MARCH 2003

peripheral file map (continued)

PERIPHERAL FILE MAP (CONTINUED)			
Timer_A3 (continued)	Capture/compare control 2	TACCTL2	0166h
	Capture/compare control 1	TACCTL1	0164h
	Capture/compare control 0	TACCTL0	0162h
	Timer_A control	TACTL	0160h
	Timer_A interrupt vector	TAIV	012Eh
Multiplier (MSP430x16x and MSP430x161x only)	Sum extend	SUMEXT	013Eh
	Result high word	RESHI	013Ch
	Result low word	RESLO	013Ah
	Second operand	OP2	0138h
	Multiply signed +accumulate/operand1	MACS	0136h
	Multiply+accumulate/operand1	MAC	0134h
	Multiply signed/operand1	MPYS	0132h
Multiply unsigned/operand1	MPY	0130h	
Flash	Flash control 3	FCTL3	012Ch
	Flash control 2	FCTL2	012Ah
	Flash control 1	FCTL1	0128h
Watchdog	Watchdog Timer control	WDTCTL	0120h
USART1 (MSP430x16x and MSP430x161x only)	Transmit buffer	U1TXBUF	07Fh
	Receive buffer	U1RXBUF	07Eh
	Baud rate	U1BR1	07Dh
	Baud rate	U1BR0	07Ch
	Modulation control	U1MCTL	07Bh
	Receive control	U1RCTL	07Ah
	Transmit control	U1TCTL	079h
	USART control	U1CTL	078h
USART0 (UART or SPI mode)	Transmit buffer	U0TXBUF	077h
	Receive buffer	U0RXBUF	076h
	Baud rate	U0BR1	075h
	Baud rate	U0BR0	074h
	Modulation control	U0MCTL	073h
	Receive control	U0RCTL	072h
	Transmit control	U0TCTL	071h
	USART control	U0CTL	070h
USART0 (I2C mode)	I2C interrupt vector	I2CIV	011Ch
	I2C slave address	I2CSA	011Ah
	I2C own address	I2COA	0118h
	I2C data	I2CDR	076h
	I2C SCLL	I2CSCLL	075h
	I2C SCLH	I2CSCLH	074h
	I2C PSC	I2CPSC	073h
	I2C data control	I2CDCTL	072h
	I2C transfer control	I2CTCTL	071h
	USART control	U0CTL	070h
	I2C data count	I2CNDAT	052h
	I2C interrupt flag	I2CIFG	051h
	I2C interrupt enable	I2CIE	050h

PRODUCT PREVIEW



peripheral file map (continued)

PERIPHERAL FILE MAP (CONTINUED)			
Comparator_A	Comparator_A port disable	CAPD	05Bh
	Comparator_A control2	CACTL2	05Ah
	Comparator_A control1	CACTL1	059h
Basic Clock	Basic clock system control2	BCSCTL2	058h
	Basic clock system control1	BCSCTL1	057h
	DCO clock frequency control	DCOCTL	056h
BrownOUT, SVS	SVS control register (reset by brownout signal)	SVSCTL	055h
Port P6	Port P6 selection	P6SEL	037h
	Port P6 direction	P6DIR	036h
	Port P6 output	P6OUT	035h
	Port P6 input	P6IN	034h
Port P5	Port P5 selection	P5SEL	033h
	Port P5 direction	P5DIR	032h
	Port P5 output	P5OUT	031h
	Port P5 input	P5IN	030h
Port P4	Port P4 selection	P4SEL	01Fh
	Port P4 direction	P4DIR	01Eh
	Port P4 output	P4OUT	01Dh
	Port P4 input	P4IN	01Ch
Port P3	Port P3 selection	P3SEL	01Bh
	Port P3 direction	P3DIR	01Ah
	Port P3 output	P3OUT	019h
	Port P3 input	P3IN	018h
Port P2	Port P2 selection	P2SEL	02Eh
	Port P2 interrupt enable	P2IE	02Dh
	Port P2 interrupt-edge select	P2IES	02Ch
	Port P2 interrupt flag	P2IFG	02Bh
	Port P2 direction	P2DIR	02Ah
	Port P2 output	P2OUT	029h
	Port P2 input	P2IN	028h
Port P1	Port P1 selection	P1SEL	026h
	Port P1 interrupt enable	P1IE	025h
	Port P1 interrupt-edge select	P1IES	024h
	Port P1 interrupt flag	P1IFG	023h
	Port P1 direction	P1DIR	022h
	Port P1 output	P1OUT	021h
	Port P1 input	P1IN	020h
Special Functions	SFR module enable 2	ME2	005h
	SFR module enable 1	ME1	004h
	SFR interrupt flag2	IFG2	003h
	SFR interrupt flag1	IFG1	002h
	SFR interrupt enable2	IE2	001h
	SFR interrupt enable1	IE1	000h

MSP430x15x, MSP430x16x, MSP430x161x MIXED SIGNAL MICROCONTROLLER

SLAS368A– OCTOBER 2002– REVISED MARCH 2003

absolute maximum ratings over operating free-air temperature (unless otherwise noted)†

Voltage applied at V_{CC} to V_{SS}	-0.3 V to 4.1 V
Voltage applied to any pin (referenced to V_{SS})	-0.3 V to $V_{CC} + 0.3$ V
Diode current at any device terminal	± 2 mA
Storage temperature, T_{stg} : (unprogrammed device)	-55°C to 150°C
(programmed device)	-40°C to 85°C

† Stresses beyond those listed under “absolute maximum ratings” may cause permanent damage to the device. These are stress ratings only, and functional operation of the device at these or any other conditions beyond those indicated under “recommended operating conditions” is not implied. Exposure to absolute-maximum-rated conditions for extended periods may affect device reliability.

NOTE: All voltages referenced to V_{SS} .

recommended operating conditions

		MIN	NOM	MAX	UNITS
Supply voltage during program execution, V_{CC} ($AV_{CC} = DV_{CC} = V_{CC}$)		MSP430F15x/F16x/161x	1.8	3.6	V
Supply voltage during flash memory programming, V_{CC} ($AV_{CC} = DV_{CC} = V_{CC}$)		MSP430F15x/16x/161x	2.7	3.6	V
Supply voltage during program execution, SVS enabled (see Note 1), V_{CC} ($AV_{CC} = DV_{CC} = V_{CC}$)		MSP430F15x/16x/161x	2	3.6	V
Supply voltage, V_{SS} ($AV_{SS} = DV_{SS} = V_{SS}$)			0	0	V
Operating free-air temperature range, T_A		MSP430F161x	-40	85	°C
LFXT1 crystal frequency, $f_{(LFXT1)}$ (see Notes 2 and 3)	LF selected, XTS=0	Watch crystal	32.768		kHz
	XT1 selected, XTS=1	Ceramic resonator	450	8000	kHz
	XT1 selected, XTS=1	Crystal	1000	8000	kHz
XT2 crystal frequency, $f_{(XT2)}$	Ceramic resonator	450	8000	kHz	
	Crystal	1000	8000		
Processor frequency (signal MCLK), $f_{(System)}$	$V_{CC} = 1.8$ V	DC	4.15		MHz
	$V_{CC} = 3.6$ V	DC	8		
Flash-timing-generator frequency, $f_{(FTG)}$		MSP430F15x/16x/161x	257	476	kHz
Cumulative program time, $t_{(CPT)}$ (see Note 4)		$V_{CC} = 2.7$ V/3.6 V MSP430F15x/16x/161x	3		ms
Mass erase time, $t_{(MEras)}$ (See the <i>flash memory, timing generator, control register FCTL2</i> section and Note 5)		$V_{CC} = 2.7$ V/3.6 V	200		ms
Low-level input voltage (TCK, TMS, TDI, RST/NMI), V_{IL} (excluding X_{in} , X_{out})		$V_{CC} = 2.2$ V/3 V	V_{SS}	$V_{SS} + 0.6$	V
High-level input voltage (TCK, TMS, TDI, RST/NMI), V_{IH} (excluding X_{in} , X_{out})		$V_{CC} = 2.2$ V/3 V	$0.8 \times V_{CC}$	V_{CC}	V
Input levels at X_{in} and X_{out}	$V_{IL}(X_{in}, X_{out})$	$V_{CC} = 2.2$ V/3 V	V_{SS}	$0.2 \times V_{CC}$	V
	$V_{IH}(X_{in}, X_{out})$		$0.8 \times V_{CC}$	V_{CC}	

- NOTES: 1. The minimum operating supply voltage is defined according to the trip point where POR is going active by decreasing the supply voltage. POR is going inactive when the V_{CC} is raised above the minimum supply voltage plus the hysteresis of the SVS circuitry.
2. In LF mode, the LFXT1 oscillator requires a watch crystal and the LFXT1 oscillator requires a 5.1-M Ω resistor from XOUT to V_{SS} when $V_{CC} < 2.5$ V. In XT1 mode, the LFXT1 and XT2 oscillators accept a ceramic resonator or a 4-MHz crystal frequency at $V_{CC} \geq 2.2$ V. In XT1 mode, the LFXT1 and XT2 oscillators accept a ceramic resonator or an 8-MHz crystal frequency at $V_{CC} \geq 2.8$ V.
3. In LF mode, the LFXT1 oscillator requires a watch crystal. In XT1 mode, LFXT1 accepts a ceramic resonator or a crystal.
4. The cumulative program time must not be exceeded during a block-write operation. This parameter is only relevant if segment write option is used.
5. The mass erase duration generated by the flash timing generator is at least 11.1 ms. The cumulative mass erase time needed is 200 ms. This can be achieved by repeating the mass erase operation until the cumulative mass erase time is met (a minimum of 19 cycles may be required).

PRODUCT PREVIEW



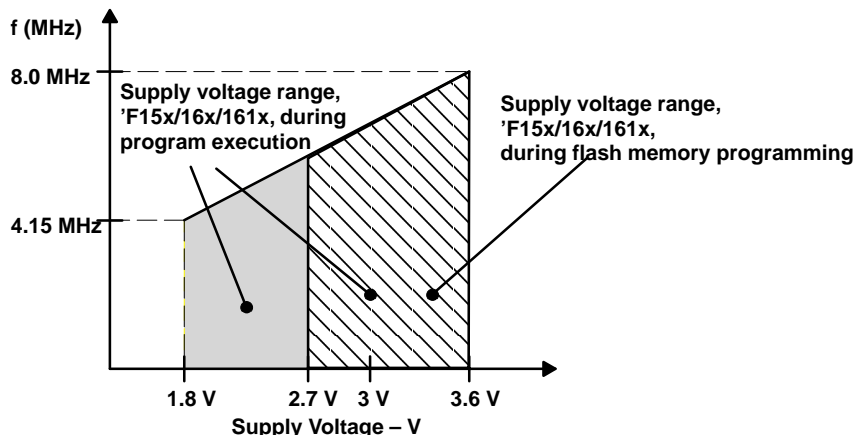

Figure 1. Frequency vs Supply Voltage, MSP430F15x/16x/161x

electrical characteristics over recommended operating free-air temperature (unless otherwise noted)

supply current into $AV_{CC} + DV_{CC}$ excluding external current

PARAMETER		TEST CONDITIONS		MIN	NOM	MAX	UNIT	
$I_{(AM)}$	Active mode, (see Note 1) $f(MCLK) = f(SMCLK) = 1$ MHz, $f(ACLK) = 32,768$ Hz XTS=0, SELM=(0,1)	F15x, F16x, F161x	$T_A = -40^{\circ}\text{C}$ to 85°C	$V_{CC} = 2.2$ V	280	350	μA	
				$V_{CC} = 3$ V	420	560		
$I_{(AM)}$	Active mode, (see Note 1) $f(MCLK) = f(SMCLK) = 4,096$ Hz, $f(ACLK) = 4,096$ Hz XTS=0, SELM=3	F15x, F16x, F161x	$T_A = -40^{\circ}\text{C}$ to 85°C	$V_{CC} = 2.2$ V	2.5	7	μA	
				$V_{CC} = 3$ V	9	20		
$I_{(LPM0)}$	Low-power mode, (LPM0) (see Note 1)	F161x	$T_A = -40^{\circ}\text{C}$ to 85°C	$V_{CC} = 2.2$ V	32	45	μA	
				$V_{CC} = 3$ V	55	70		
$I_{(LPM2)}$	Low-power mode, (LPM2), $f(MCLK) = f(SMCLK) = 0$ MHz, $f(ACLK) = 32.768$ Hz, SCG0 = 0		$T_A = -40^{\circ}\text{C}$ to 85°C	$V_{CC} = 2.2$ V	11	14	μA	
				$V_{CC} = 3$ V	17	22		
$I_{(LPM3)}$	Low-power mode, (LPM3) $f(MCLK) = f(SMCLK) = 0$ MHz, $f(ACLK) = 32,768$ Hz, SCG0 = 1 (see Note 2)		$T_A = -40^{\circ}\text{C}$ to 85°C	$V_{CC} = 2.2$ V	$T_A = -40^{\circ}\text{C}$	0.8	1.5	μA
					$T_A = 25^{\circ}\text{C}$	0.9	1.5	
					$T_A = 85^{\circ}\text{C}$	1.6	2.8	
				$V_{CC} = 3$ V	$T_A = -40^{\circ}\text{C}$	1.8	2.2	μA
					$T_A = 25^{\circ}\text{C}$	1.6	1.9	
					$T_A = 85^{\circ}\text{C}$	2.3	3.9	
$I_{(LPM4)}$	Low-power mode, (LPM4) $f(MCLK) = 0$ MHz, $f(SMCLK) = 0$ MHz, $f(ACLK) = 0$ Hz, SCG0 = 1		$T_A = -40^{\circ}\text{C}$ to 85°C	$V_{CC} = 2.2$ V	$T_A = -40^{\circ}\text{C}$	0.1	0.5	μA
					$T_A = 25^{\circ}\text{C}$	0.1	0.5	
					$T_A = 85^{\circ}\text{C}$	0.8	2.5	
				$V_{CC} = 3$ V	$T_A = -40^{\circ}\text{C}$	0.1	0.5	μA
					$T_A = 25^{\circ}\text{C}$	0.1	0.5	
					$T_A = 85^{\circ}\text{C}$	0.8	2.5	

NOTES: 1. Timer_B is clocked by $f(DCOCLK) = 1$ MHz. All inputs are tied to 0 V or to V_{CC} . Outputs do not source or sink any current.
2. Timer_B is clocked by $f(ACLK) = 32,768$ Hz. All inputs are tied to 0 V or to V_{CC} . Outputs do not source or sink any current. The current consumption in LPM2 and LPM3 are measured with ACLK selected.

MSP430x15x, MSP430x16x, MSP430x161x MIXED SIGNAL MICROCONTROLLER

SLAS368A– OCTOBER 2002– REVISED MARCH 2003

electrical characteristics over recommended operating free-air temperature (unless otherwise noted) (continued)

Current consumption of active mode versus system frequency, F-version

$$I_{(AM)} = I_{(AM)} [1 \text{ MHz}] \times f(\text{System}) [\text{MHz}]$$

Current consumption of active mode versus supply voltage, F-version

$$I_{(AM)} = I_{(AM)} [3 \text{ V}] + 175 \mu\text{A/V} \times (V_{CC} - 3 \text{ V})$$

SCHMITT-trigger inputs – Ports P1, P2, P3, P4, P5, and P6

PARAMETER		TEST CONDITIONS	MIN	TYP	MAX	UNIT
V _{IT+}	Positive-going input threshold voltage	V _{CC} = 2.2 V	1.1		1.5	V
		V _{CC} = 3 V	1.5		1.9	
V _{IT-}	Negative-going input threshold voltage	V _{CC} = 2.2 V	0.4		0.9	V
		V _{CC} = 3 V	0.90		1.3	
V _{hys}	Input voltage hysteresis (V _{IT+} – V _{IT-})	V _{CC} = 2.2 V	0.3		1.1	V
		V _{CC} = 3 V	0.5		1	

standard inputs – RST/NMI; JTAG: TCK, TMS, TDI, TDO/TDI

PARAMETER		TEST CONDITIONS	MIN	TYP	MAX	UNIT
V _{IL}	Low-level input voltage	V _{CC} = 2.2 V / 3 V	V _{SS}		V _{SS} +0.6	V
V _{IH}	High-level input voltage		0.8×V _{CC}		V _{CC}	V

outputs – Ports P1, P2, P3, P4, P5, and P6

PARAMETER		TEST CONDITIONS	MIN	TYP	MAX	UNIT
V _{OH}	High-level output voltage	I _{OH(max)} = –1 mA, V _{CC} = 2.2 V, See Note 1	V _{CC} –0.25		V _{CC}	V
		I _{OH(max)} = –3.4 mA, V _{CC} = 2.2 V, See Note 2	V _{CC} –0.6		V _{CC}	
		I _{OH(max)} = –1 mA, V _{CC} = 3 V, See Note 1	V _{CC} –0.25		V _{CC}	
		I _{OH(max)} = –3.4 mA, V _{CC} = 3 V, See Note 2	V _{CC} –0.6		V _{CC}	
V _{OL}	Low-level output voltage	I _{OL(max)} = 1.5 mA, V _{CC} = 2.2 V, See Note 1	V _{SS}		V _{SS} +0.25	V
		I _{OL(max)} = 6 mA, V _{CC} = 2.2 V, See Note 2	V _{SS}		V _{SS} +0.6	
		I _{OL(max)} = 1.5 mA, V _{CC} = 3 V, See Note 1	V _{SS}		V _{SS} +0.25	
		I _{OL(max)} = 6 mA, V _{CC} = 3 V, See Note 2	V _{SS}		V _{SS} +0.6	

- NOTES: 1. The maximum total current, I_{OH(max)} and I_{OL(max)}, for all outputs combined, should not exceed ±12 mA to satisfy the maximum specified voltage drop.
 2. The maximum total current, I_{OH(max)} and I_{OL(max)}, for all outputs combined, should not exceed ±48 mA to satisfy the maximum specified voltage drop.

PRODUCT PREVIEW



outputs – Ports P1, P2, P3, P4, P5, and P6 (continued)

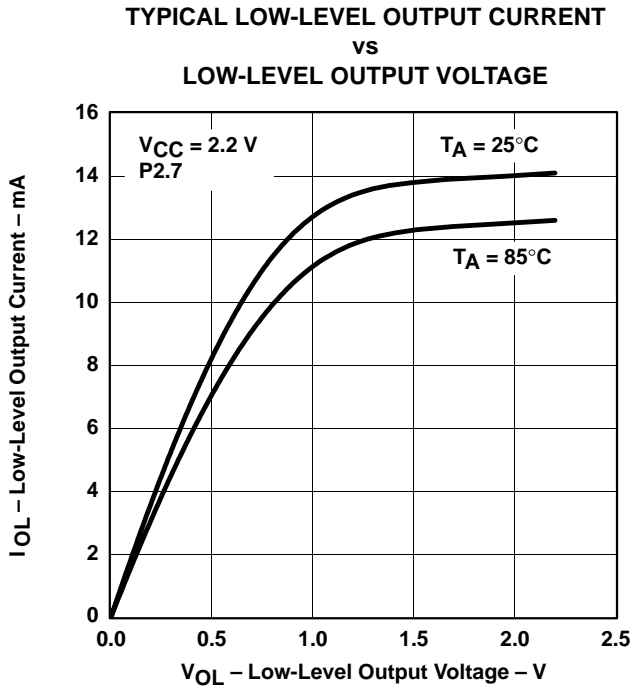

Figure 2

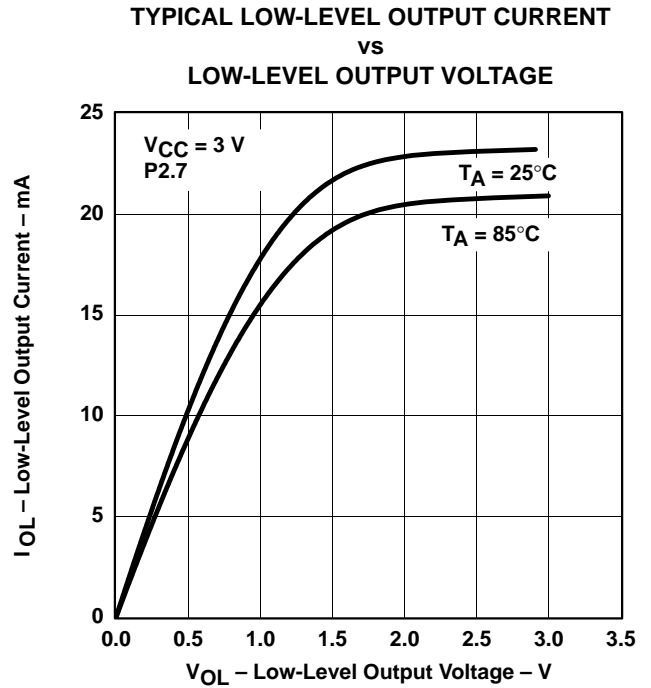

Figure 3

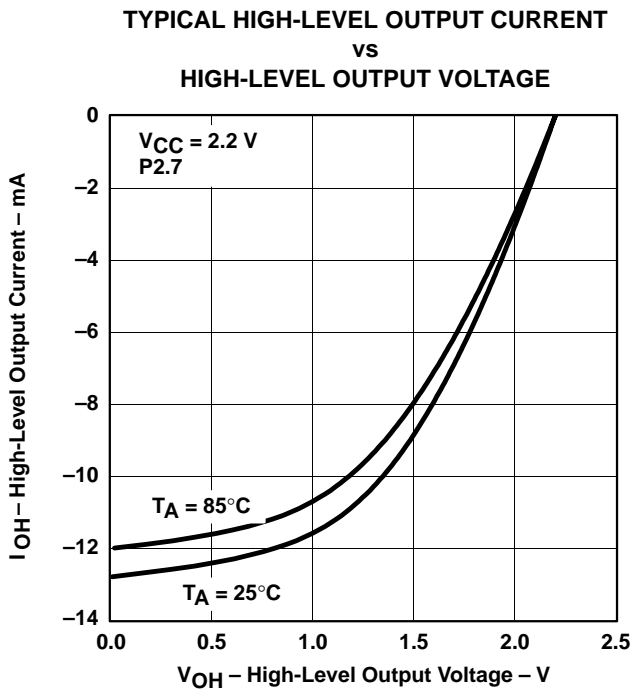

Figure 4

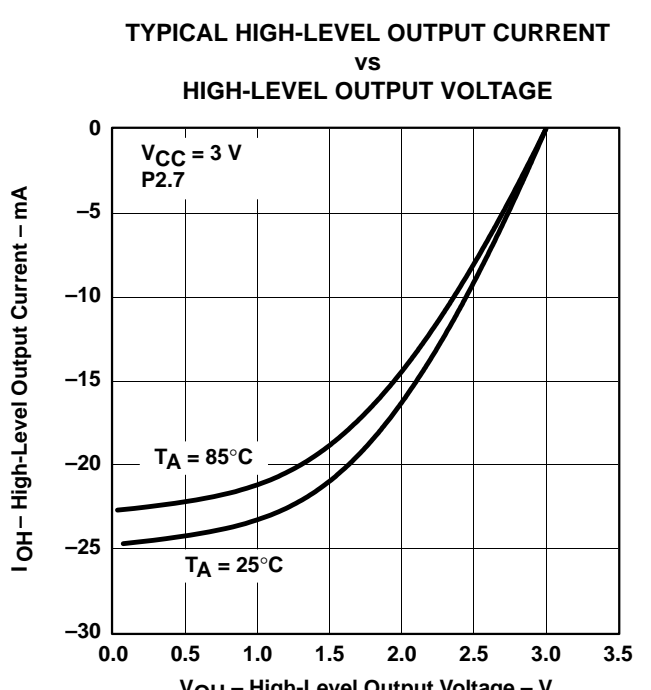

Figure 5

MSP430x15x, MSP430x16x, MSP430x161x MIXED SIGNAL MICROCONTROLLER

SLAS368A– OCTOBER 2002– REVISED MARCH 2003

electrical characteristics over recommended operating free-air temperature (unless otherwise noted) (continued)

output frequency

PARAMETER		TEST CONDITIONS		MIN	TYP	MAX	UNIT
$f_{(Px.y)}$	$(1 \leq x \leq 6, 0 \leq y \leq 7)$	$C_L = 20 \text{ pF}$ $I_L = \pm 1.5 \text{ mA}$	$V_{CC} = 2.2 \text{ V}$	DC		5	MHz
			$V_{CC} = 3 \text{ V}$	DC		7.5	
$f_{(ACLK)}$	P2.0/ACLK, P5.6/ACLK	$C_L = 20 \text{ pF}$	$V_{CC} = 2.2 \text{ V}$	DC		5	MHz
$f_{(MCLK)}$	P5.4/MCLK, P1.4/SMCLK, P5.5/SMCLK		$V_{CC} = 3 \text{ V}$	DC		7.5	
$f_{(SMCLK)}$							
$t_{(Xdc)}$	Duty cycle of output frequency	$P1.0/TACLK$ $C_L = 20 \text{ pF}$ $V_{CC} = 2.2 \text{ V} / 3 \text{ V}$	$f_{(ACLK)} = f_{(LFXT1)} = f_{(XT1)}$	40%		60%	
			$f_{(ACLK)} = f_{(LFXT1)} = f_{(LF)}$	30%		70%	
			$f_{(ACLK)} = f_{(LFXT1)}$		50%		
		$P1.1/TA0/MCLK$, $C_L = 20 \text{ pF}$, $V_{CC} = 2.2 \text{ V} / 3 \text{ V}$	$f_{(MCLK)} = f_{(XT1)}$	40%		60%	
			$f_{(MCLK)} = f_{(DCOCLK)}$	50%– 15 ns	50%	50%+ 15 ns	
			$f_{(SMCLK)} = f_{(XT2)}$	40%		60%	
$P1.4/TBCLK/SMCLK$, $C_L = 20 \text{ pF}$, $V_{CC} = 2.2 \text{ V} / 3 \text{ V}$	$f_{(SMCLK)} = f_{(DCOCLK)}$	50%– 15 ns	50%	50%+ 15 ns			

inputs $Px.x$, TAx , TBx

PARAMETER		TEST CONDITIONS	V_{CC}	MIN	TYP	MAX	UNIT
$t_{(int)}$	External interrupt timing	Port P1, P2: P1.x to P2.x, external trigger signal for the interrupt flag, (see Note 1)	2.2 V/3 V	1.5			cycle
			2.2 V	62			ns
			3 V	50			
$t_{(cap)}$	Timer_A, Timer_B capture timing	TA0, TA1, TA2 (see Note 2)	2.2 V/3 V	1.5			cycle
			2.2 V	62			ns
		TB0, TB1, TB2, TB3, TB4, TB5, TB6 (see Note 3)	3 V	50			
$f_{(TAext)}$	Timer_A, Timer_B clock frequency externally applied to pin	TACLK, TBCLK, INCLK: $t_{(H)} = t_{(L)}$	2.2 V			8	MHz
$f_{(TBext)}$			3 V			10	
$f_{(TAint)}$	Timer_A, Timer_B clock frequency	SMCLK or ACLK signal selected	2.2 V			8	MHz
$f_{(BTAint)}$			3 V			10	

- NOTES: 1. The external signal sets the interrupt flag every time the minimum $t_{(int)}$ cycle and time parameters are met. It may be set even with trigger signals shorter than $t_{(int)}$. Both the cycle and timing specifications must be met to ensure the flag is set. $t_{(int)}$ is measured in MCLK cycles.
2. The external capture signal triggers the capture event every time the minimum $t_{(cap)}$ cycle and time parameters are met. A capture may be triggered with capture signals even shorter than $t_{(cap)}$. Both the cycle and timing specifications must be met to ensure a correct capture of the 16-bit timer value and to ensure the flag is set.
3. Seven capture/compare registers in 'x16x/161x and three capture/compare registers in 'x15x.

wake-up LPM3

PARAMETER		TEST CONDITIONS	MIN	TYP	MAX	UNIT
$t_{(LPM3)}$	Delay time	$V_{CC} = 2.2 \text{ V} / 3 \text{ V}$			6	μs

PRODUCT PREVIEW



electrical characteristics over recommended operating free-air temperature (unless otherwise noted) (continued)

leakage current (see Note 1)

PARAMETER		TEST CONDITIONS		MIN	TYP	MAX	UNIT
$I_{lkg}(P1.x)$	Leakage current	Port P1	Port 1: $V(P1.x)$ (see Note 2)	$V_{CC} = 2.2 V/3 V$		± 50	nA
$I_{lkg}(P2.x)$		Port P2	Port 2: $V(P2.3) V(P2.4)$ (see Note 2)			± 50	
$I_{lkg}(P6.x)$		Port P6	Port 6: $V(P6.x)$ (see Note 2)			± 50	

- NOTES: 1. The leakage current is measured with V_{SS} or V_{CC} applied to the corresponding pin(s), unless otherwise noted.
2. The port pin must be selected as input and there must be no optional pullup or pulldown resistor.

RAM

PARAMETER	TEST CONDITIONS	MIN	TYP	MAX	UNIT
V_{RAMh}	CPU HALTED (see Note 1)	1.6			V

- NOTE 1: This parameter defines the minimum supply voltage when the data in program memory RAM remain unchanged. No program execution should take place during this supply voltage condition.

Comparator_A (see Note 1)

PARAMETER		TEST CONDITIONS		MIN	TYP	MAX	UNIT	
$I_{(DD)}$		CAON=1, CARSEL=0, CAREF=0	$V_{CC} = 2.2 V$	25	40	μA		
			$V_{CC} = 3 V$	45	60			
$I_{(Ref ladder/Ref diode)}$		CAON=1, CARSEL=0, CAREF=1/2/3, no load at P2.3/CA0/TA1 and P2.4/CA1/TA2	$V_{CC} = 2.2 V$	30	50	μA		
			$V_{CC} = 3 V$	45	71			
$V_{(IC)}$	Common-mode input voltage	CAON =1	$V_{CC} = 2.2 V/3 V$	0	$V_{CC}-1$	V		
$V_{(Ref025)}$	$\frac{\text{Voltage @ } 0.25 V_{CC} \text{ node}}{V_{CC}}$	PCA0=1, CARSEL=1, CAREF=1, no load at P2.3/CA0/TA1 and P2.4/CA1/TA2	$V_{CC} = 2.2 V/3 V$	0.23	0.24	0.25		
$V_{(Ref050)}$	$\frac{\text{Voltage @ } 0.5 V_{CC} \text{ node}}{V_{CC}}$	PCA0=1, CARSEL=1, CAREF=2, no load at P2.3/CA0/TA1 and P2.4/CA1/TA2	$V_{CC} = 2.2 V/3 V$	0.47	0.48	0.5		
$V_{(RefVT)}$	See Figure 7.	PCA0=1, CARSEL=1, CAREF=3, no load at P2.3/CA0/TA1 and P2.4/CA1/TA2 $T_A = 85^\circ C$	$V_{CC} = 2.2 V$	390	480	540	mV	
			$V_{CC} = 3 V$	400	490	550		
$V_{(offset)}$	Offset voltage	See Note 2	$V_{CC} = 2.2 V/3 V$	-30		30	mV	
V_{hys}	Input hysteresis	CAON=1	$V_{CC} = 2.2 V/3 V$	0	0.7	1.4	mV	
$t_{(response LH)}$		$T_A = 25^\circ C$, Overdrive 10 mV, Without filter: CAF=0	$V_{CC} = 2.2 V$	130	210	300	ns	
			$V_{CC} = 3 V$	80	150	240		
			$T_A = 25^\circ C$, Overdrive 10 mV, With filter: CAF=1	$V_{CC} = 2.2 V$	1.4	1.9	3.4	μs
				$V_{CC} = 3 V$	0.9	1.5	2.6	
$t_{(response HL)}$		$T_A = 25^\circ C$, Overdrive 10 mV, without filter: CAF=0	$V_{CC} = 2.2 V$	130	210	300	ns	
			$V_{CC} = 3 V$	80	150	240		
			$T_A = 25^\circ C$, Overdrive 10 mV, with filter: CAF=1	$V_{CC} = 2.2 V$	1.4	1.9	3.4	μs
				$V_{CC} = 3 V$	0.9	1.5	2.6	

- NOTES: 1. The leakage current for the Comparator_A terminals is identical to $I_{lkg}(Px.x)$ specification.
2. The input offset voltage can be cancelled by using the CAEX bit to invert the Comparator_A inputs on successive measurements. The two successive measurements are then summed together.

MSP430x15x, MSP430x16x, MSP430x161x MIXED SIGNAL MICROCONTROLLER

SLAS368A– OCTOBER 2002– REVISED MARCH 2003

electrical characteristics over recommended operating free-air temperature (unless otherwise noted) (continued)

PRODUCT PREVIEW

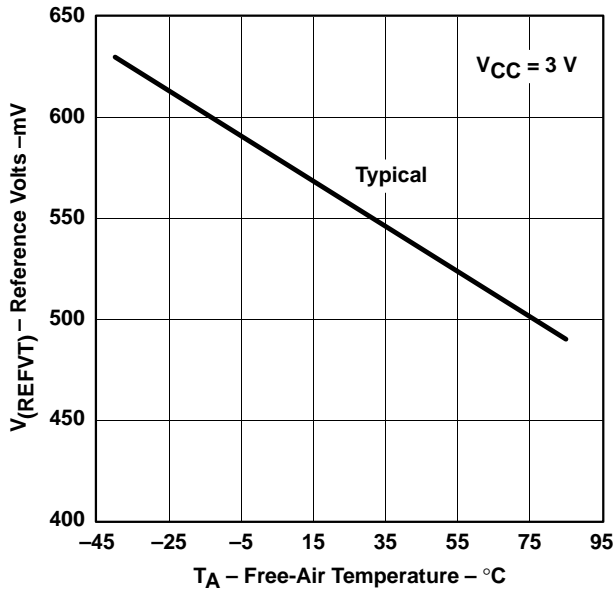

Figure 6. $V_{(REFVT)}$ vs Temperature, $V_{CC} = 3V$

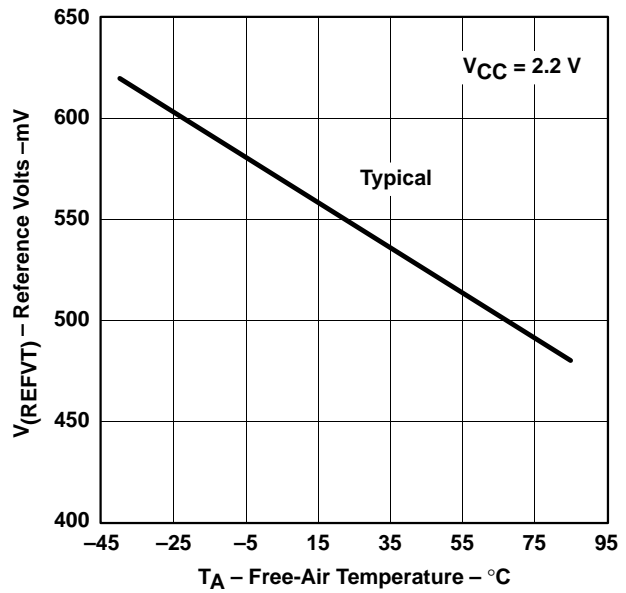

Figure 7. $V_{(REFVT)}$ vs Temperature, $V_{CC} = 2.2V$

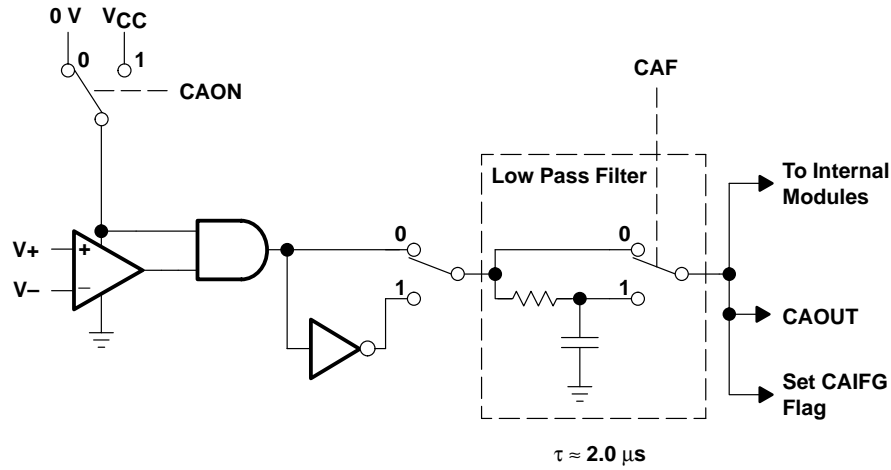

Figure 8. Block Diagram of Comparator_A Module

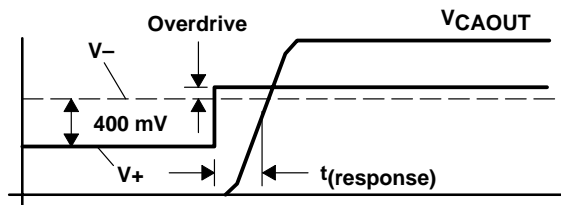

Figure 9. Overdrive Definition

electrical characteristics over recommended operating free-air temperature (unless otherwise noted) (continued)

POR/brownout reset (BOR) (see Notes 1 and 2)

PARAMETER	TEST CONDITIONS	MIN	TYP	MAX	UNIT
$t_d(\text{BOR})$				2000	μs
$V_{\text{CC}}(\text{Start})$	$dV_{\text{CC}}/dt \leq 3 \text{ V/s}$ (see Figure 10)		$0.7 \times V_{(\text{B_IT-})}$		V
$V_{(\text{B_IT-})}$	$dV_{\text{CC}}/dt \leq 3 \text{ V/s}$ (see Figure 10 through Figure 12)			1.71	V
$V_{\text{hys}}(\text{B_IT-})$	$dV_{\text{CC}}/dt \leq 3 \text{ V/s}$ (see Figure 10)	70	130	180	mV
$t(\text{reset})$	Pulse length needed at RST/NMI pin to accepted reset internally, $V_{\text{CC}} = 2.2 \text{ V}/3 \text{ V}$	2			μs

- NOTES: 1. The current consumption of the brownout module is already included in the I_{CC} current consumption data. The voltage level $V_{(\text{B_IT-})} + V_{\text{hys}}(\text{B_IT-})$ is $\leq 1.8 \text{ V}$.
 2. During powerup, the CPU begins code execution following a period of t_{BOR} (delay) after $V_{\text{CC}} = V_{(\text{B_IT-})} + V_{\text{hys}}(\text{B_IT-})$. The default DCO settings must not be changed until $V_{\text{CC}} \geq V_{\text{CC}}(\text{min})$. See the *MSP430x1xx Family User's Guide* (SLAU049) for more information on the brownout/SVS circuit.

typical characteristics

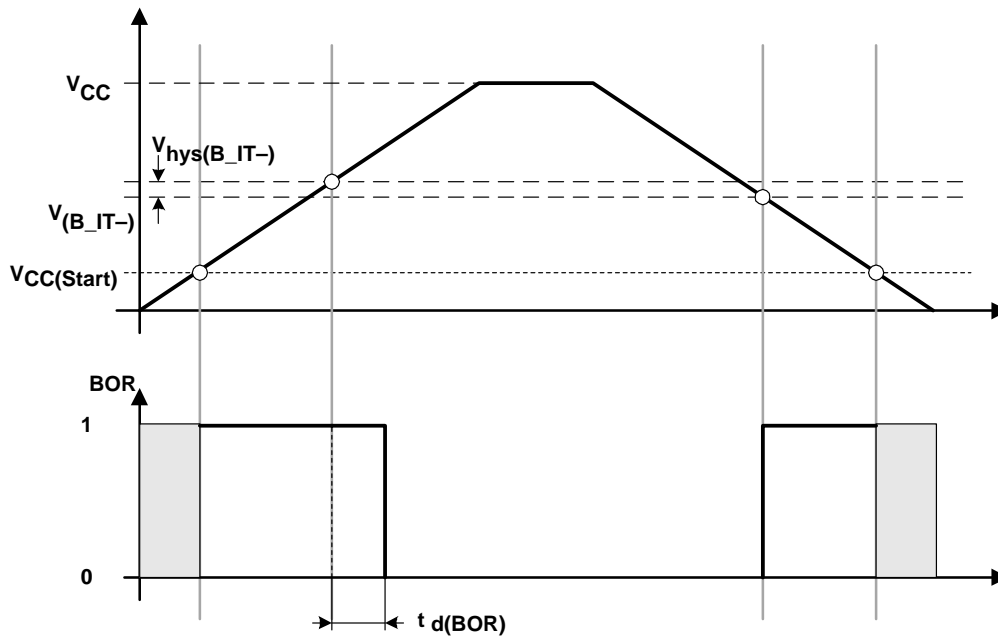

Figure 10. POR/Brownout Reset (BOR) vs Supply Voltage

MSP430x15x, MSP430x16x, MSP430x161x MIXED SIGNAL MICROCONTROLLER

SLAS368A– OCTOBER 2002– REVISED MARCH 2003

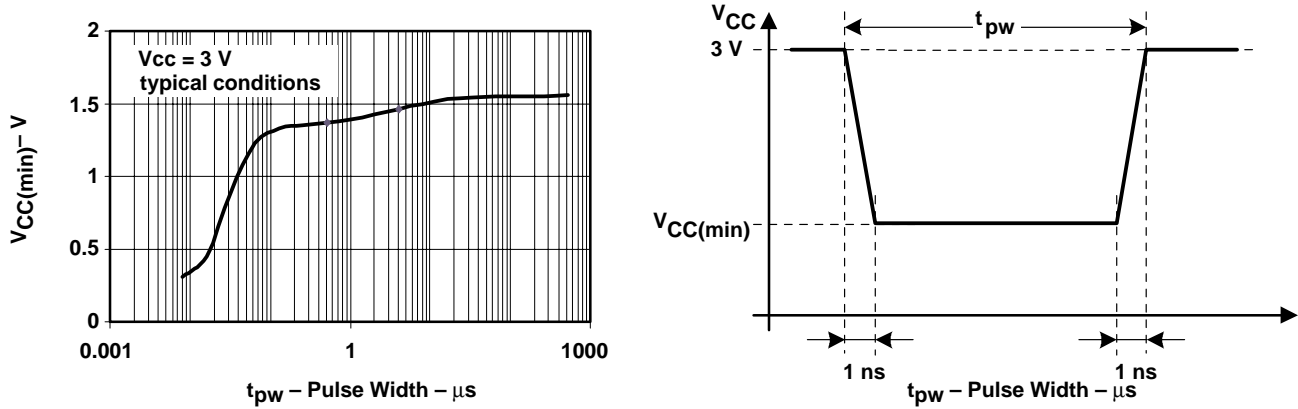

Figure 11. $V_{CC(min)}$ Level With a Square Voltage Drop to Generate a POR/Brownout Signal

typical characteristics

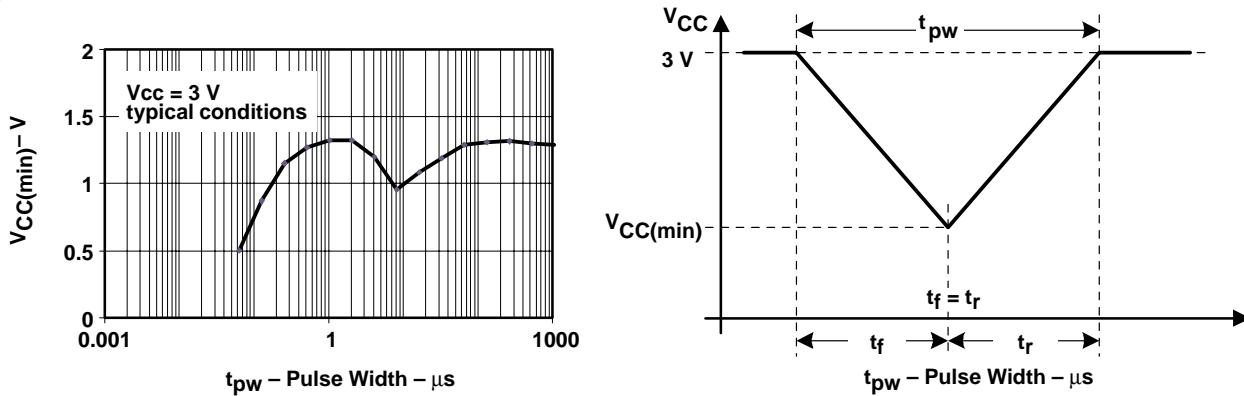

Figure 12. $V_{CC(min)}$ Level With a Triangle Voltage Drop to Generate a POR/Brownout Signal

PRODUCT PREVIEW

electrical characteristics over recommended operating free-air temperature (unless otherwise noted)

SVS (supply voltage supervisor/monitor)

PARAMETER	TEST CONDITIONS		MIN	NOM	MAX	UNIT
t(SVSR)	dV _{CC} /dt > 30 V/ms (see Figure 13)		5		150	μs
	dV _{CC} /dt ≤ 30 V/ms				2000	μs
t _d (SVSon)	SVSON, switch from VLD = 0 to VLD ≠ 0, V _{CC} = 3 V		20		150	μs
t _{settle}	VLD ≠ 0 [†]				12	μs
V(SVSstart)	VLD ≠ 0, V _{CC} /dt ≤ 3 V/s (see Figure 13)			1.55	1.7	V
V _{hys} (B_IT-)	V _{CC} /dt ≤ 3 V/s (see Figure 13)	VLD = 1	70	120	155	mV
		VLD = 2 .. 14	V(SVS_IT-) × 0.004		V(SVS_IT-) × 0.008	
	V _{CC} /dt ≤ 3 V/s (see Figure 13), External voltage applied on A7		VLD = 15	4.4		10.4
V(SVS_IT-)	V _{CC} /dt ≤ 3 V/s (see Figure 13 and Figure 14)	VLD = 1	1.8	1.9	2.05	V
		VLD = 2	1.94	2.1	2.25	
		VLD = 3	2.05	2.2	2.37	
		VLD = 4	2.14	2.3	2.48	
		VLD = 5	2.24	2.4	2.6	
		VLD = 6	2.33	2.5	2.71	
		VLD = 7	2.46	2.65	2.86	
		VLD = 8	2.58	2.8	3	
		VLD = 9	2.69	2.9	3.13	
		VLD = 10	2.83	3.05	3.29	
		VLD = 11	2.94	3.2	3.42	
		VLD = 12	3.11	3.35	3.61 [†]	
		VLD = 13	3.24	3.5	3.76 [†]	
		VLD = 14	3.43	3.7 [†]	3.99 [†]	
	V _{CC} /dt ≤ 3 V/s (see Figure 13 and Figure 14), External voltage applied on A7		VLD = 15	1.1	1.2	
I _{CC} (SVS) (see Note 1)	VLD ≠ 0, V _{CC} = 2.2 V/3 V			10	15	μA

[†] The recommended operating voltage range is limited to 3.6 V.

[‡] t_{settle} is the settling time that the comparator o/p needs to have a stable level after VLD is switched VLD ≠ 0 to a different VLD value somewhere between 2 and 15. The overdrive is assumed to be > 50 mV.

NOTE 1: The current consumption of the SVS module is not included in the I_{CC} current consumption data.

MSP430x15x, MSP430x16x, MSP430x161x MIXED SIGNAL MICROCONTROLLER

SLAS368A– OCTOBER 2002– REVISED MARCH 2003

PRODUCT PREVIEW

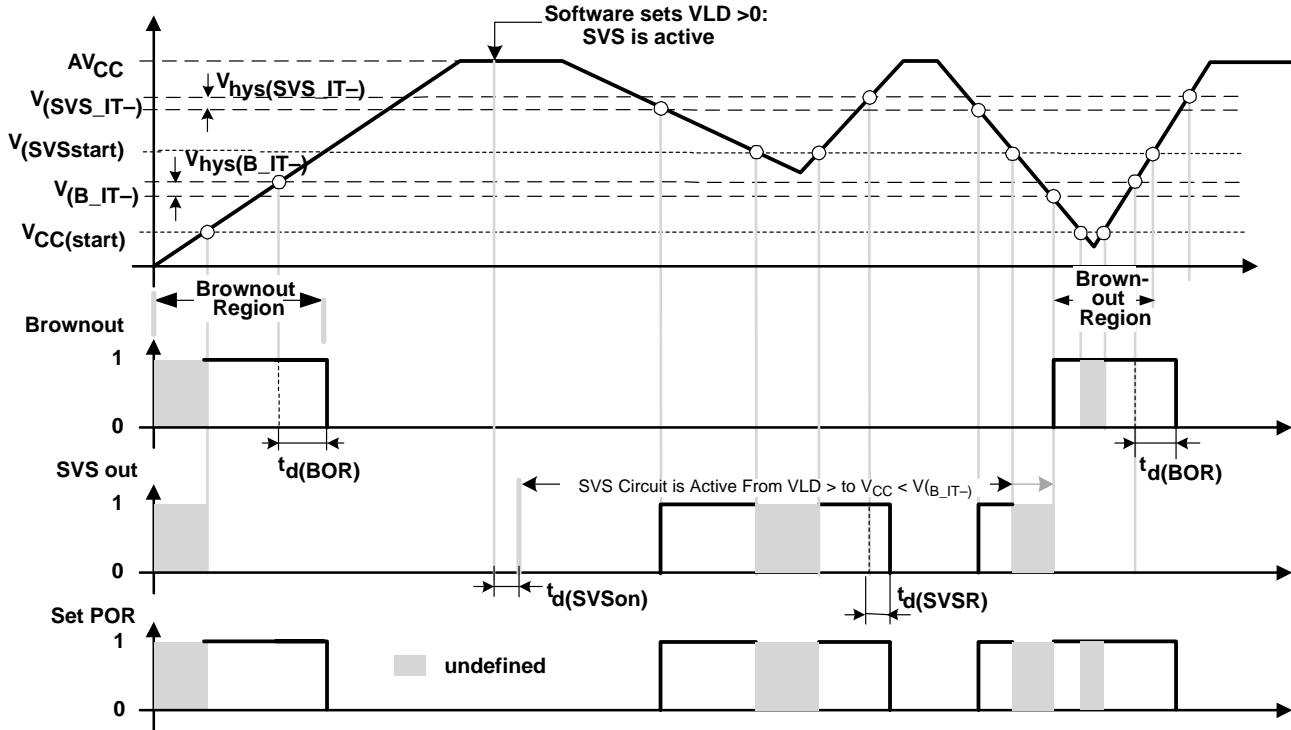

Figure 13. SVS Reset (SVSR) vs Supply Voltage

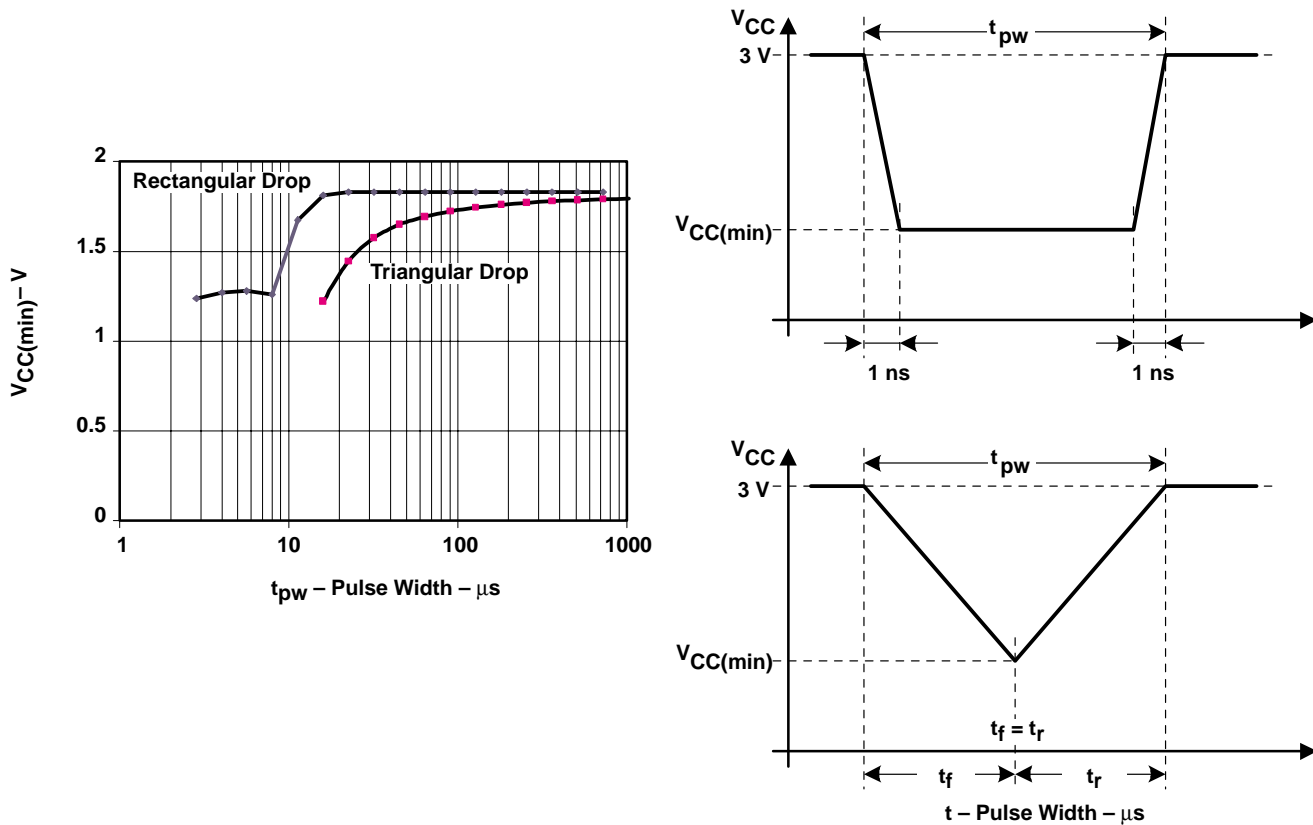

Figure 14. $V_{CC(min)}$: Square Voltage Drop and Triangle Voltage Drop to Generate an SVS Signal (VLD = 1)



POST OFFICE BOX 655303 • DALLAS, TEXAS 75265

electrical characteristics over recommended operating free-air temperature (unless otherwise noted) (continued)

DCO (see Note 1)

PARAMETER	TEST CONDITIONS	MIN	NOM	MAX	UNIT	
f _(DCO03)	R _{sel} = 0, DCO = 3, MOD = 0, DCOR = 0, T _A = 25°C	V _{CC} = 2.2 V	0.08	0.12	0.15	MHz
		V _{CC} = 3 V	0.08	0.13	0.16	
f _(DCO13)	R _{sel} = 1, DCO = 3, MOD = 0, DCOR = 0, T _A = 25°C	V _{CC} = 2.2 V	0.14	0.19	0.23	MHz
		V _{CC} = 3 V	0.14	0.18	0.22	
f _(DCO23)	R _{sel} = 2, DCO = 3, MOD = 0, DCOR = 0, T _A = 25°C	V _{CC} = 2.2 V	0.22	0.30	0.36	MHz
		V _{CC} = 3 V	0.22	0.28	0.34	
f _(DCO33)	R _{sel} = 3, DCO = 3, MOD = 0, DCOR = 0, T _A = 25°C	V _{CC} = 2.2 V	0.37	0.49	0.59	MHz
		V _{CC} = 3 V	0.37	0.47	0.56	
f _(DCO43)	R _{sel} = 4, DCO = 3, MOD = 0, DCOR = 0, T _A = 25°C	V _{CC} = 2.2 V	0.61	0.77	0.93	MHz
		V _{CC} = 3 V	0.61	0.75	0.90	
f _(DCO53)	R _{sel} = 5, DCO = 3, MOD = 0, DCOR = 0, T _A = 25°C	V _{CC} = 2.2 V	1	1.2	1.5	MHz
		V _{CC} = 3 V	1	1.3	1.5	
f _(DCO63)	R _{sel} = 6, DCO = 3, MOD = 0, DCOR = 0, T _A = 25°C	V _{CC} = 2.2 V	1.6	1.9	2.2	MHz
		V _{CC} = 3 V	1.69	2.0	2.29	
f _(DCO73)	R _{sel} = 7, DCO = 3, MOD = 0, DCOR = 0, T _A = 25°C	V _{CC} = 2.2 V	2.4	2.9	3.4	MHz
		V _{CC} = 3 V	2.7	3.2	3.65	
f _(DCO47)	R _{sel} = 4, DCO = 7, MOD = 0, DCOR = 0, T _A = 25°C	V _{CC} = 2.2 V/3 V	f _{DCO40} × 1.7	f _{DCO40} × 2.1	f _{DCO40} × 2.5	MHz
f _(DCO77)	R _{sel} = 7, DCO = 7, MOD = 0, DCOR = 0, T _A = 25°C	V _{CC} = 2.2 V	4	4.5	4.9	MHz
		V _{CC} = 3 V	4.4	4.9	5.4	
S _(Rsel)	S _R = f _{Rsel+1} / f _{Rsel}	V _{CC} = 2.2 V/3 V	1.35	1.65	2	
S _(DCO)	S _{DCO} = f _{DCO+1} / f _{DCO}	V _{CC} = 2.2 V/3 V	1.07	1.12	1.16	
D _t	Temperature drift, R _{sel} = 4, DCO = 3, MOD = 0 (see Note 2)	V _{CC} = 2.2 V	-0.31	-0.36	-0.40	%°C
		V _{CC} = 3 V	-0.33	-0.38	-0.43	
D _V	Drift with V _{CC} variation, R _{sel} = 4, DCO = 3, MOD = 0 (see Note 2)	V _{CC} = 2.2 V/3 V	0	5	10	%/V

NOTES: 1. The DCO frequency may not exceed the maximum system frequency defined by parameter processor frequency, f_(System).
2. This parameter is not production tested.

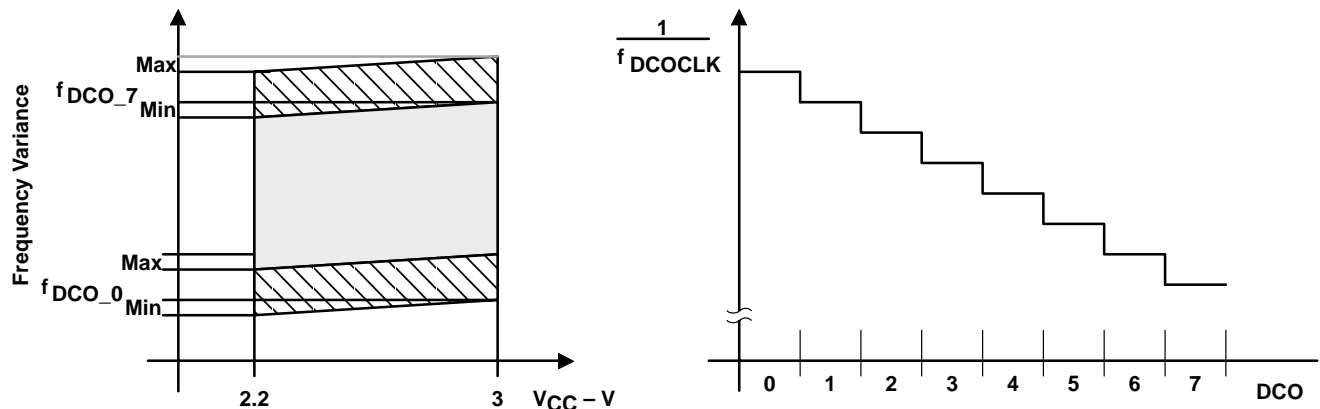

Figure 15. DCO Characteristics

MSP430x15x, MSP430x16x, MSP430x161x MIXED SIGNAL MICROCONTROLLER

SLAS368A– OCTOBER 2002– REVISED MARCH 2003

electrical characteristics over recommended operating free-air temperature (unless otherwise noted) (continued)

main DCO characteristics

- Individual devices have a minimum and maximum operation frequency. The specified parameters for fDCOx0 to fDCOx7 are valid for all devices.
- All ranges selected by Rsel(n) overlap with Rsel(n+1): Rsel0 overlaps with Rsel1, ... Rsel6 overlaps with Rsel7.
- DCO control bits DCO0, DCO1, and DCO2 have a step size as defined by parameter SDCO.
- Modulation control bits MOD0 to MOD4 select how often fDCO+1 is used within the period of 32 DCOCLK cycles. The frequency f(DCO) is used for the remaining cycles. The frequency is an average equal to $f(\text{DCO}) \times (2^{\text{MOD}/32})$.

crystal oscillator, LFXT1 oscillator (see Note 1)

PARAMETER		TEST CONDITIONS	MIN	NOM	MAX	UNIT
XCIN	Integrated input capacitance	XTS=0; LF oscillator selected, V _{CC} = 2.2 V/3 V		12		pF
		XTS=1; XT1 oscillator selected, V _{CC} = 2.2 V/3 V		2		
XCOUT	Integrated output capacitance	XTS=0; LF oscillator selected, V _{CC} = 2.2 V/3 V		12		pF
		XTS=1; XT1 oscillator selected, V _{CC} = 2.2 V/3 V		2		
XINL	Input levels at XIN, XOUT	V _{CC} = 2.2 V/3 V	V _{SS}		0.2 × V _{CC}	V
XINH		V _{CC} = 2.2 V/3 V	0.8 × V _{CC}		V _{CC}	V

NOTE 1: The oscillator needs capacitors at both terminals, with values specified by the crystal manufacturer.

crystal oscillator, XT2 oscillator (see Note 1)

PARAMETER		TEST CONDITIONS	MIN	NOM	MAX	UNIT
XCIN	Integrated input capacitance	V _{CC} = 2.2 V/3 V		2		pF
XCOUT	Integrated output capacitance	V _{CC} = 2.2 V/3 V		2		pF
XINL	Input levels at XIN, XOUT	V _{CC} = 2.2 V/3 V	V _{SS}		0.2 × V _{CC}	V
XINH		V _{CC} = 2.2 V/3 V	0.8 × V _{CC}		V _{CC}	V

NOTE 1: The oscillator needs capacitors at both terminals, with values specified by the crystal manufacturer.

USART0, USART1 (see Note 1)

PARAMETER		TEST CONDITIONS	MIN	NOM	MAX	UNIT
t _(τ)	USART0/USART1: deglitch time	V _{CC} = 2.2 V	200	430	800	ns
		V _{CC} = 3 V	150	280	500	

NOTE 1: The signal applied to the USART0/USART1 receive signal/terminal (URXD0/1) should meet the timing requirements of t_(τ) to ensure that the URXS flip-flop is set. The URXS flip-flop is set with negative pulses meeting the minimum-timing condition of t_(τ). The operating conditions to set the flag must be met independently from this timing constraint. The deglitch circuitry is active only on negative transitions on the URXD0/1 line.

PRODUCT PREVIEW



electrical characteristics over recommended operating free-air temperature (unless otherwise noted) (continued)

12-bit ADC, power supply and input range conditions (see Note 1)

PARAMETER		TEST CONDITIONS	MIN	NOM	MAX	UNIT	
V_{CC}	Analog supply voltage	V_{CC} and DV_{CC} are connected together V_{SS} and DV_{SS} are connected together $V(V_{SS}) = V(DV_{SS}) = 0\text{ V}$	2.2		3.6		
V_{REF+}	Positive built-in reference voltage output	REF2_5 V = 1 for 2.5 V built-in reference REF2_5 V = 0 for 1.5 V built-in reference $I(V_{REF+}) \leq I(V_{REF+})_{max}$	3 V	2.4	2.5	2.6	V
			2.2 V/ 3 V	1.44	1.5	1.56	
	Positive built-in reference, V_{CC} minimum voltage	REF2_5V = 0, $I(V_{REF+}) \leq 1\text{ mA}$		2.2			
		REF2_5V = 1, $I(V_{REF+}) \leq 0.5\text{ mA}$		$V_{REF+} + 0.15$			
		REF2_5V = 1, $I(V_{REF+}) \leq 1\text{ mA}$		$V_{REF+} + 0.15$			
$I(V_{REF+})$	Load-current out of V_{REF+} terminal		2.2 V	0.01	-0.5	mA	
			3 V		-1		
$I_L(V_{REF+})$	Load-current regulation V_{REF+} terminal	$I(V_{REF+}) = 500\text{ }\mu\text{A} \pm 100\text{ }\mu\text{A}$ Analog input voltage -0.75 V ; REF2_5 V = 0	2.2 V		± 2	LSB	
		$I(V_{REF+}) = 500\text{ }\mu\text{A} \pm 100\text{ }\mu\text{A}$ Analog input voltage -1.25 V ; REF2_5 V = 1	3 V		± 2		
$I_{DL}(V_{REF+})$	Load current regulation V_{REF+} terminal	$I(V_{REF+}) = 100\text{ }\mu\text{A} \rightarrow 900\text{ }\mu\text{A}$, $V_{CC} = 3\text{ V}$, $a_x \sim 0.5 \times V_{REF+}$ Error of conversion result $\leq 1\text{ LSB}$	$C_{V_{REF+}} = 5\text{ }\mu\text{F}$		20	ns	
V_{eREF+}	Positive external reference voltage input	$V_{eREF+} > V_{REF-} - V_{eREF-}$ (see Note 2)	1.4		V_{AVCC}	V	
V_{REF-} / V_{eREF-}	Negative external reference voltage input	$V_{eREF+} > V_{REF-} - V_{eREF-}$ (see Note 3)	0		1.2	V	
$(V_{eREF+} - V_{REF-} / V_{eREF-})$	Differential external reference voltage input	$V_{eREF+} > V_{REF-} - V_{eREF-}$ (see Note 4)	1.4		V_{AVCC}	V	
$V(P6.x/Ax)$	Analog input voltage range (see Note 5)	All P6.0/A0 to P6.7/A7 terminals. Analog inputs selected in ADC12MCTLx register and P6Sel.x=1 $0 \leq x \leq 7$; $V(V_{SS}) \leq V_{P6.x/Ax} \leq V(V_{AVCC})$	0		V_{AVCC}	V	
I_{ADC12}	Operating supply current into V_{CC} terminal (see Note 6)	$f_{ADC12CLK} = 5.0\text{ MHz}$ ADC12ON = 1, REFON = 0 SHT0=0, SHT1=0, ADC12DIV=0	2.2 V	0.65	1.3	mA	
			3 V	0.8	1.6		
I_{REF+}	Operating supply current into V_{CC} terminal (see Note 7)	$f_{ADC12CLK} = 5.0\text{ MHz}$ ADC12ON = 0, REFON = 1, REF2_5V = 1	3 V	0.5	0.8	mA	
I_{REF+}	Operating supply current (see Note 7)	$f_{ADC12CLK} = 5.0\text{ MHz}$ ADC12ON = 0, REFON = 1, REF2_5V = 0	2.2 V	0.5	0.8	mA	
			3 V	0.5	0.8		

- NOTES:
- The leakage current is defined in the leakage current table with P6.x/Ax parameter.
 - The accuracy limits the minimum positive external reference voltage. Lower reference voltage levels may be applied with reduced accuracy requirements.
 - The accuracy limits the maximum negative external reference voltage. Higher reference voltage levels may be applied with reduced accuracy requirements.
 - The accuracy limits minimum external differential reference voltage. Lower differential reference voltage levels may be applied with reduced accuracy requirements.
 - The analog input voltage range must be within the selected reference voltage range V_{R+} to V_{R-} for valid conversion results.
 - The internal reference supply current is not included in current consumption parameter I_{ADC12} .
 - The internal reference current is supplied via terminal V_{CC} . Consumption is independent of the ADC12ON control bit, unless a conversion is active. The REFON bit enables to settle the built-in reference before starting an A/D conversion.

MSP430x15x, MSP430x16x, MSP430x161x MIXED SIGNAL MICROCONTROLLER

SLAS368A– OCTOBER 2002– REVISED MARCH 2003

electrical characteristics over recommended operating free-air temperature (unless otherwise noted) (continued)

12-bit ADC, built-in reference (see Note 1)

PARAMETER		TEST CONDITIONS		MIN	NOM	MAX	UNIT
I_{VeREF+}	Static input current (see Note 2)	$0V \leq V_{eREF+} \leq V_{AVCC}$	2.2 V/3 V			± 1	μA
I_{VREF-}/V_{eREF-}	Static input current (see Note 2)	$0V \leq V_{eREF-} \leq V_{AVCC}$	2.2 V/3 V			± 1	μA
C_{VREF+}	Capacitance at pin V_{REF+} (see Note 3)	REFON =1, $0 mA \leq I_{VREF+} \leq I_{V(REF)+}(max)$	2.2 V/3 V	5	10		μF
C_i	Input capacitance (see Note 4)	Only one terminal can be selected at one time, P6.x/Ax	2.2 V			40	pF
Z_i	Input MUX ON resistance(see Note 4)	$0V \leq V_{Ax} \leq V_{AVCC}$	3 V			2000	Ω
T_{REF+}	Temperature coefficient of built-in reference	$I_{V(REF)+}$ is a constant in the range of $0 mA \leq I_{V(REF)+} \leq 1 mA$	2.2 V/3 V			± 100	ppm/ $^{\circ}C$

- NOTES: 1. The voltage source on V_{eREF+} and V_{REF-}/V_{eREF-} needs to have low dynamic impedance for 12-bit accuracy to allow the charge to settle for this accuracy.
2. The external reference is used during conversion to charge and discharge the capacitance array. The dynamic impedance should follow the recommendations on analog-source impedance to allow the charge to settle for 12-bit accuracy.
3. The internal buffer operational amplifier and the accuracy specifications require an external capacitor.
4. The input capacitance is also the dynamic load for an external reference during conversion. The dynamic impedance of the reference supply should follow the recommendations on analog-source impedance to allow the charge to settle for 12-bit accuracy. All INL and DNL tests use two capacitors between pins V_{REF+} and AV_{SS} and V_{REF-}/V_{eREF-} and AV_{SS} : 10 μF tantalum and 100 nF ceramic.

PRODUCT PREVIEW



electrical characteristics over recommended operating free-air temperature (unless otherwise noted) (continued)

12-bit ADC, timing parameters

PARAMETER		TEST CONDITIONS	MIN	NOM	MAX	UNIT
$t_{REF(ON)}$	Settle time of internal reference voltage (see Figure 16 and Note 1)	$I_{V(REF)+} = 0.5 \text{ mA}$, $C_{V(REF)+} = 10 \text{ }\mu\text{F}$, $V_{REF+} = 1.5 \text{ V}$, $V_{AVCC} = 2.2 \text{ V}$			17	ms
$f(ADC12CLK)$		Error of conversion result $\leq \pm 2 \text{ LSB}$ (vs. the conversion result taken with $f(ADC12CLK) = 5 \text{ MHz}$)	2.2V/ 3V	5		MHz
$f(ADC12OSC)$		$ADC12DIV=0$ [$f(ADC12CLK)$ $=f(ADC12OSC)$]	2.2V/ 3V	3.7	6.3	MHz
$t_{CONVERT}$	Conversion time	$V_{CC(min)} \leq V_{AVCC} \leq V_{CC(max)}$, $C_{VREF+} \geq 5 \text{ }\mu\text{F}$, Internal oscillator, $f_{OSC} = 3.7 \text{ MHz to } 6.3 \text{ MHz}$	2.2V/ 3V	2.06	3.51	μs
	Conversion time	$V_{CC(min)} \leq V_{AVCC} \leq V_{CC(max)}$, External $f_{ADC12CLK}$ from ACLK or MCLK or SMCLK: $ADC12SSEL \neq 0$		$13 \times ADC12DIV \times$ $1/f_{ADC12CLK}$		μs
$t_{ADC12ON}$	Settle time of the ADC	$V_{CC(min)} \leq V_{AVCC} \leq V_{CC(max)}$ (see Note 2)			100	ns
t_{Sample}	Sampling time	$V_{AVCC(min)} \leq V_{AVCC} \leq V_{AVCC(max)}$ $R_{i(source)} = 400 \text{ }\Omega$, $Z_i = 1000 \text{ }\Omega$, $C_i = 30 \text{ pF}$ $\tau = [R_{i(source)} \times Z_i] \times C_i$ (see Note 3)	3V	1220		ns
			2.2V	1400		

- NOTES: 1. The condition is that the error in a conversion started after $t_{REF(ON)}$ is less than $\pm 0.5 \text{ LSB}$. The settling time depends on the external capacitive load.
2. The condition is that the error in a conversion started after $t_{ADC12ON}$ is less than $\pm 0.5 \text{ LSB}$. The reference and input signal are already settled.
3. Ten Tau (τ) are needed to get an error of less than $\pm 0.5 \text{ LSB}$. $t_{Sample} = 10 \times (R_i + Z_i) \times C_i + 800 \text{ ns}$

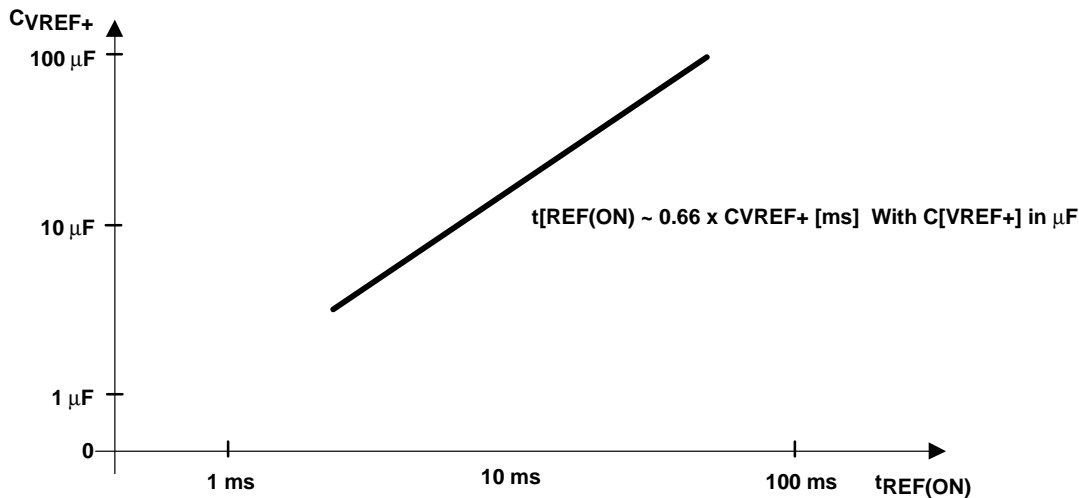

Figure 16. Typical Settling Time of Internal Reference $t_{REF(ON)}$ vs External Capacitor on V_{REF+}

MSP430x15x, MSP430x16x, MSP430x161x MIXED SIGNAL MICROCONTROLLER

SLAS368A– OCTOBER 2002– REVISED MARCH 2003

electrical characteristics over recommended operating free-air temperature (unless otherwise noted) (continued)

12-bit ADC, linearity parameters

PARAMETER	TEST CONDITIONS	MIN	NOM	MAX	UNIT
E _(I) Integral linearity error	1.4 V ≤ (V _{eREF+} - V _{REF-} - V _{eREF-}) min ≤ 1.6 V	2.2 V/3 V		±2	LSB
	1.6 V < [V _{eREF+} - V _{REF-} - V _{eREF-}] min ≤ [V(AV _{CC})]			±1.7	
E _D Differential linearity error	(V _{eREF+} - V _{REF-} - V _{eREF-}) min ≤ (V _{eREF+} - V _{REF-} - V _{eREF-}), C(V _{REF+}) = 10 μF (tantalum) and 100 nF (ceramic)	2.2 V/3 V		±1	LSB
E _O Offset error	(V _{eREF+} - V _{REF-} - V _{eREF-}) min ≤ (V _{eREF+} - V _{REF-} - V _{eREF-}), Internal impedance of source R _i < 100 Ω, C(V _{REF+}) = 10 μF (tantalum) and 100 nF (ceramic)	2.2 V/3 V		±2 ±4	LSB
E _G Gain error	(V _{eREF+} - V _{REF-} - V _{eREF-}) min ≤ (V _{eREF+} - V _{REF-} - V _{eREF-}), C(V _{REF+}) = 10 μF (tantalum) and 100 nF (ceramic)	2.2 V/3 V		±1.1 ±2	LSB
E _T Total unadjusted error	(V _{eREF+} - V _{REF-} - V _{eREF-}) min ≤ (V _{eREF+} - V _{REF-} - V _{eREF-}), C(V _{REF+}) = 10 μF (tantalum) and 100 nF (ceramic)	2.2 V/3 V		±2 ±5	LSB

12-bit ADC, temperature sensor and built-in V_{mid}

PARAMETER	TEST CONDITIONS	MIN	NOM	MAX	UNIT
I _{SENSOR} Operating supply current into AV _{CC} terminal (see Note 1)	V _{REFON} = 0, INCH = 0Ah, ADC12ON=NA, T _A = 25°C	2.2 V	40	120	μA
		3 V	60	160	
V _{SENSOR}	ADC12ON = 1, INCH = 0Ah, T _A = 0°C	2.2 V	986	986±5%	mV
		3 V	986	986±5%	
T _{CSENSOR}	ADC12ON = 1, INCH = 0Ah	2.2 V	3.55	3.55±3%	mV/°C
		3 V	3.55	3.55±3%	
t _{SENSOR(sample)} Sample time required if channel 10 is selected (see Note 2)	ADC12ON = 1, INCH = 0Ah, Error of conversion result ≤ 1 LSB	2.2 V	30		μs
		3 V	30		
I _{VMID} Current into divider at channel 11	ADC12ON = 1, INCH = 0Bh, (see Note 3)	2.2 V		NA	μA
		3 V		NA	
V _{MID} AV _{CC} divider at channel 11	ADC12ON = 1, INCH = 0Bh, V _{MID} is ~0.5 × V _{AVCC}	2.2 V	1.1	1.1±0.04	V
		3 V	1.5	1.50±0.04	
t _{ON(VMID)} On-time if channel 11 is selected (see Note 4)	ADC12ON = 1, INCH = 0Bh, Error of conversion result ≤ 1 LSB	2.2 V		NA	ns
		3 V		NA	

- NOTES: 1. The sensor current I_{SENSOR} is consumed if (ADC12ON = 1 and V_{REFON}=1), or (ADC12ON=1 AND INCH=0Ah and sample signal is high). Therefore it includes the constant current through the sensor and the reference.
2. The typical equivalent impedance of the sensor is 51 kΩ. The sample time needed is the sensor-on time t_{SENSOR(ON)}.
3. No additional current is needed. The V_{MID} is used during sampling.
4. The on-time t_{ON(VMID)} is identical to sampling time t_{Sample}; no additional on time is needed.

PRODUCT PREVIEW



electrical characteristics over recommended operating free-air temperature (unless otherwise noted) (continued)

12-bit DAC, supply specifications

PARAMETER		TEST CONDITIONS	V _{CC}	MIN	TYP	MAX	UNIT
AV _{CC}	Analog supply voltage	AV _{CC} = DV _{CC} , AV _{SS} = DV _{SS} = 0 V		2.20		3.60	V
I _{DD}	Supply Current (see Notes 1 and 2)	DAC12AMP _x ={0,1}, DAC12IR=0, DAC12_xDAT=0800h	2.2V/3V		TBD	TBD	μA
		DAC12AMP _x =2, DAC12IR=0, DAC12_xDAT=0800h	2.2V/3V		120	TBD	
		DAC12AMP _x ={2, 3, 4}, DAC12IR=1, DAC12_xDAT=0800h, V _{eREF+} =V _{REF+} =AV _{CC}	2.2V/3V		160	TBD	
		DAC12AMP _x ={5, 6}, DAC12IR=1, DAC12_xDAT=0800h, V _{eREF+} =V _{REF+} =AV _{CC}	2.2V/3V		275	TBD	
		DAC12AMP _x =7, DAC12IR=1, DAC12_xDAT=0800h, V _{eREF+} =V _{REF+} =AV _{CC}	2.2V/3V		725	TBD	
PSRR	Power supply sensitivity (see Notes 3 and 4)	DAC12_xDAT = 800h, V _{REF} = 1.5 V ΔAV _{CC} = 100mV	2.2V		-70		dB
		DAC12_xDAT = 800h, V _{REF} = 1.5 V or 2.5 V ΔAV _{CC} = 100mV	3V				

- NOTES: 1. No load at the output pin, DAC0 or DAC1, assuming that the control bits for the shared pins are set properly.
 2. I_{Ri} is included in the supply current specification, I_{DD}.
 3. PSRR = 20*log{V_{DAC12_xOUT}(AV_{CC}) - V_{DAC12_xOUT}(AV_{CC} +/- ΔAV_{CC})}.
 4. V_{REF} is applied externally. The internal reference is not used.

MSP430x15x, MSP430x16x, MSP430x161x MIXED SIGNAL MICROCONTROLLER

SLAS368A– OCTOBER 2002– REVISED MARCH 2003

electrical characteristics over recommended operating free-air temperature (unless otherwise noted) (continued)

12-bit DAC, linearity specifications (see Figure 17)

PARAMETER		TEST CONDITIONS	V _{CC}	MIN	TYP	MAX	UNIT
Resolution		(12-bit Monotonic)		12			bits
INL	Integral nonlinearity (see Note 1)	V _{ref} = 1.5 V or AV _{CC} DAC12AMPx = 7, DAC12IR = 1	2.2V	±4.0	±8.0	LSB	
		V _{ref} = 1.5 V, 2.5 V or AV _{CC} DAC12AMPx = 7, DAC12IR = 1	3V				
DNL	Differential nonlinearity (see Note 1)	V _{ref} = 1.5 V or AV _{CC} DAC12AMPx = 7, DAC12IR = 1	2.2V	±1.0	LSB		
		V _{ref} = 1.5 V, 2.5 V or AV _{CC} DAC12AMPx = 7, DAC12IR = 1	3V				
E _O	Offset voltage w/o calibration (see Notes 1, 2)	V _{ref} = 1.5 V or AV _{CC} DAC12AMPx = 7, DAC12IR = 1	2.2V	±21	mV		
		V _{ref} = 1.5 V, 2.5 V or AV _{CC} DAC12AMPx = 7, DAC12IR = 1	3V				
	Offset voltage with calibration (see Notes 1, 2)	V _{ref} = 1.5 V or AV _{CC} DAC12AMPx = 7, DAC12IR = 1	2.2V			±1.5	
		V _{ref} = 1.5 V, 2.5 V or AV _{CC} DAC12AMPx = 7, DAC12IR = 1	3V				
dE(ZS)/dT	Zero-scale error temperature coefficient (see Note 1)		2.2V/3V	30	µV/C		
E _G	Gain error (see Note 1)		2.2V/3V	±3.50	% FS		
dE(G)/dT	Gain temperature coefficient (see Note 1)		2.2V/3V	10	ppm/°C		
t _{Offset_Cal}	Time for offset calibration (see Note 3)	DAC12.xAmp=2	2.2V/3V	25.0	ms		
		DAC12.xAmp=3,5	2.2V/3V	8.0			
		DAC12.xAmp=4,6,7	2.2V/3V	1.5			

- NOTES: 1. Parameter calculated from the best-fit curve. The best-fit curve method is used to deliver coefficients "a" and "b" of the first order equation: $y = a + b \cdot x$. $V_{DAC12_OUTx} = E_O + (1 - E_G/100) \cdot (DAC12_xDAT/4096) \cdot V_{eREF+}$, DAC12IR = 1.
 2. The offset calibration works on the output operational amplifier. Offset Calibration is triggered setting bit DAC12CALON
 3. The offset calibration can be done if DAC12AMPx = {2, 3, 4, 5, 6, 7}. The output operational amplifier is switched off with DAC12AMPx = {0, 1}. It is recommended that the DAC12 module be configured prior to initiating calibration.

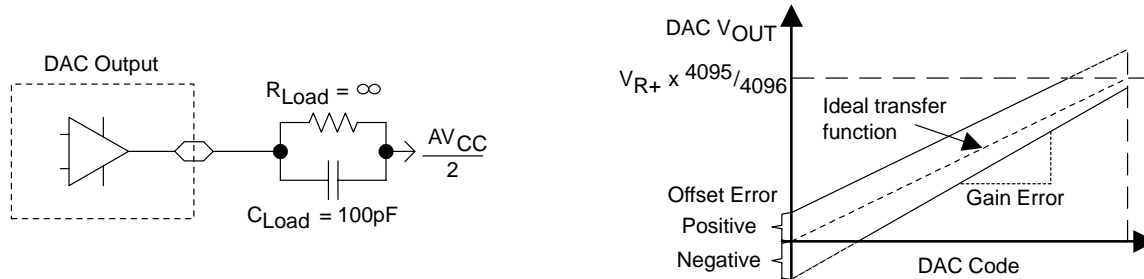

Figure 17. Linearity Test Load Conditions and Gain/Offset Definition

PRODUCT PREVIEW

electrical characteristics over recommended operating free-air temperature (unless otherwise noted) (continued)

12-bit DAC, output specifications

PARAMETER		TEST CONDITIONS	VCC	MIN	TYP	MAX	UNIT
V _O	Output voltage range (see Note 1)	R _{Load} = 3 kΩ, V _{REF+} = AV _{CC} , DAC12_xDAT = 0FFh, DAC12IR = 1, DAC12AMPx = 7	2.2V/3V	AV _{CC} -0.13		AV _{CC}	V
		No Load, V _{REF+} = AV _{CC} , DAC12_xDAT = 0h, DAC12IR = 1, DAC12AMPx = 7	2.2V/3V	0		0.025	
		No Load, V _{REF+} = AV _{CC} , DAC12_xDAT = 0FFh, DAC12IR = 1, DAC12AMPx = 7	2.2V/3V	AV _{CC} -0.1		AV _{CC}	
C _L (DAC12)	DAC12 load capacitance		2.2V/3V			100	pF
R _L (DAC12)	DAC12 load resistance		2.2V/3V	2.2			kΩ
R _{O/P} (DAC12) (see Figure 18)	Output Resistance V _{OUT} <0.3V or V _{OUT} >AV _{CC} -0.3V	R _{Load} = 3 kΩ, V _{O/P} (DAC12)< 0.3V, DAC12AMPx = 2	2.2V/3V			200	Ω
		R _{Load} = 3 kΩ, V _{O/P} (DAC12)>AV _{CC} -0.3V	2.2V/3V			200	
	Output Resistance 0.3V<V _{OUT} <AV _{CC} -0.3V	R _{Load} = 3 kΩ, 0.3V ≤ V _{O/P} (DAC12) ≤ AV _{CC} - 0.3V	2.2V/3V			4	

NOTES: 1. Data is valid after the offset calibration of the output amplifier.

12-bit DAC, reference input specifications

PARAMETER		TEST CONDITIONS	VCC	MIN	TYP	MAX	UNIT
V _{REF+}	Reference input voltage range	DAC12_xIR=0, (see Notes 1 and 2)	2.2V/3V		AV _{CC} /3	AV _{CC} +0.2	V
		DAC12_xIR=1, (see Notes 3 and 4)	2.2V/3V		AV _{CC}	AV _{CC} +0.2	
R _i (V _{REF+}), R _i (V _{REF+})	Reference input resistance (see Figure 18)	DAC12_0 IR=1, DAC12_1 IR = 0	2.2V/3V	40	48	56	kΩ
		DAC12_0 IR=0, DAC12_1 IR = 1	2.2V/3V				
		DAC12_0 IR=DAC12_1 IR = 0	2.2V/3V	20	MΩ		

- NOTES: 1. For a full-scale output, the reference input voltage can be as high as 1/3 of the maximum output voltage swing (AV_{CC}).
 2. The maximum voltage applied at reference input voltage terminal V_{REF+} = [AV_{CC} - V_{E(O)}] / [3*(1 + E_G/100)].
 3. For a full-scale output, the reference input voltage can be as high as the maximum output voltage swing (AV_{CC}).
 4. The maximum voltage applied at reference input voltage terminal V_{REF+} = [AV_{CC} - V_{E(O)}] / (1 + E_G/100).

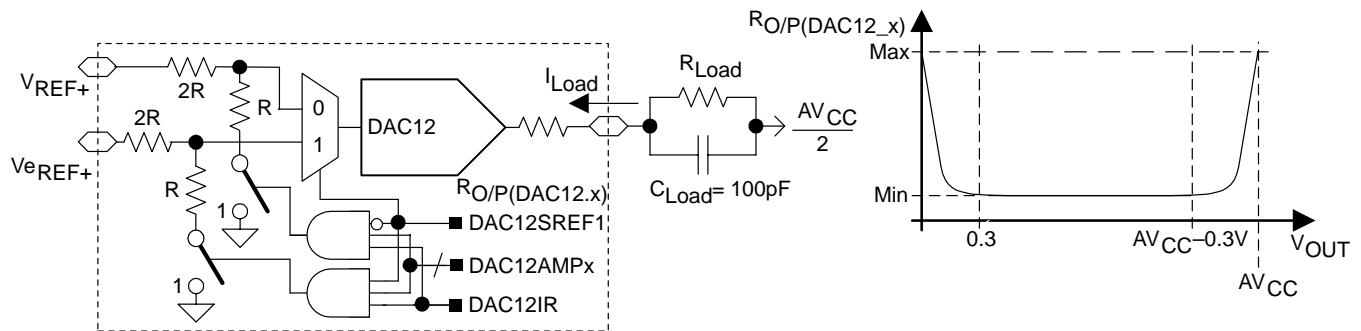

Figure 18. DAC12_x Reference Input and DAC Output Resistance Tests

MSP430x15x, MSP430x16x, MSP430x161x MIXED SIGNAL MICROCONTROLLER

SLAS368A– OCTOBER 2002– REVISED MARCH 2003

electrical characteristics over recommended operating free-air temperature (unless otherwise noted)

12-bit DAC, dynamic specifications ($T_A = 25^\circ\text{C}$ unless otherwise noted), (see Figure 19)

PARAMETER	TEST CONDITIONS		VCC	MIN	TYP	MAX	UNIT
t_{ON} DAC12 on-time	DAC12_xDAT = 800h, Error $V(O) < \pm 0.5$ LSB	DAC12.xAmp=0 \rightarrow {2, 3, 4}	2.2V/3V		TBD	TBD	μs
		DAC12.xAmp=0 \rightarrow {5, 6}	2.2V/3V		TBD	TBD	
		DAC12.xAmp=0 \rightarrow 7	2.2V/3V		TBD	TBD	
$t_{S(FS)}$ Settling time, full-scale	DAC12_xDAT = 80h \rightarrow F7Fh \rightarrow 80h	DAC12.xAmp=2	2.2V/3V		TBD	TBD	μs
		DAC12.xAmp=3,5	2.2V/3V		TBD	TBD	
		DAC12.xAmp=4,6,7	2.2V/3V		TBD	TBD	
$t_{S(C-C)}$ Settling time, code to code	DAC12_xDAT = 3F8h \rightarrow 408h \rightarrow 3F8h BF8h \rightarrow C08h \rightarrow BF8h	DAC12.xAmp=2	2.2V/3V			TBD	μs
		DAC12.xAmp=3,5	2.2V/3V			TBD	
		DAC12.xAmp=4,6,7	2.2V/3V			TBD	
SR Slew Rate	DAC12_xDAT = 80h \rightarrow F7Fh \rightarrow 80h	DAC12.xAmp=2	2.2V/3V	0.08			$\text{V}/\mu\text{s}$
		DAC12.xAmp=3,5	2.2V/3V	0.50			
		DAC12.xAmp=4,6,7	2.2V/3V	2.00			
Glitch energy: code-to-code	DAC12_xDAT = 3F8h \rightarrow 408h \rightarrow 3F8h BF8h \rightarrow C08h \rightarrow BF8h	DAC12.xAmp=2	2.2V/3V		25		$\text{nV}\cdot\text{s}$
		DAC12.xAmp=3,5	2.2V/3V		25		
		DAC12.xAmp=4,6,7	2.2V/3V		25		

NOTES: 1. Slew rate applies to output voltage steps $\geq 200\text{mV}$.

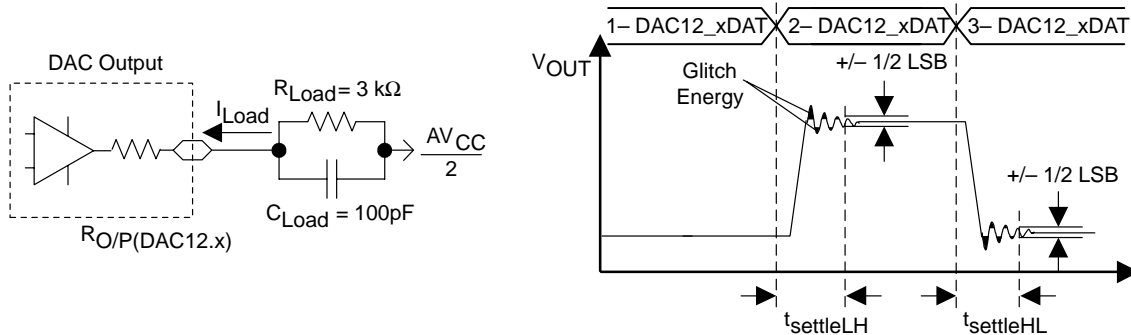

Figure 19. Settling Time and Glitch Energy Testing

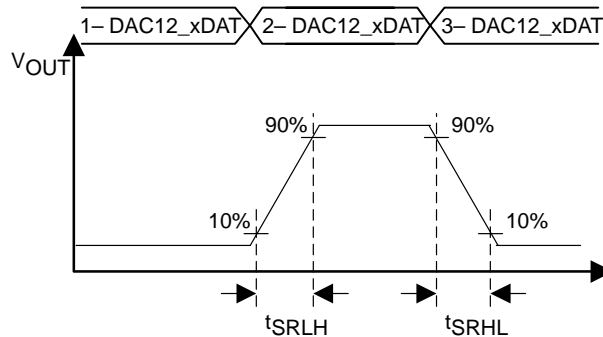

Figure 20. Slew Rate Testing

electrical characteristics over recommended operating free-air temperature (unless otherwise noted)

12-bit DAC, dynamic specifications continued ($T_A = 25^\circ\text{C}$ unless otherwise noted)

PARAMETER		TEST CONDITIONS	VCC	MIN	TYP	MAX	UNIT
SNR	Signal to noise ratio	DAC12AMPx = 2 (see Notes 1, 3, 5)	2.2V/3V		72		dB
		DAC12AMPx = {3, 5} (see Notes 1, 4, 5)	2.2V/3V		72		
		DAC12AMPx = {4, 6, 7} (see Notes 1, 4, 5)	2.2V/3V		72		
SINAD	Signal to noise and distortion	DAC12AMPx = 2 (see Notes 1, 2, 3, 5)	2.2V/3V		60		dB
		DAC12AMPx = {3, 5} (see Notes 1, 2, 4, 5)	2.2V/3V		60		
		DAC12AMPx = {4, 6, 7} (see Notes 1, 2, 4, 5)	2.2V/3V		60		
THD	Total harmonic distortion	DAC12AMPx = 2 (see Note 3, 5)	2.2V/3V		-60		dB
		DAC12AMPx = {3, 5} (see Note 4, 5)	2.2V/3V		-60		
		DAC12AMPx = {4, 6, 7} (see Note 4, 5)	2.2V/3V		-60		
SFDR	Spurious free dynamic range	DAC12AMPx = 2 (see Note 3, 5)	2.2V/3V		76		dB
		DAC12AMPx = {3, 5} (see Note 4, 5)	2.2V/3V		76		
		DAC12AMPx = {4, 6, 7} (see Note 4, 5)	2.2V/3V		76		

- NOTES:
1. Simulated with ideal resistor string, limited resolution for FFT and low pass filter improves quantization noise
 2. Data is based on INL \leq +/-4 LSB
 3. Measured with DAC12-generated 25Hz sine wave, 400 samples/period, $V_{PP} \sim 0.9 \cdot AV_{CC}$, $V_{DC} = AV_{CC}/2$, $V_{eREF+} = AV_{CC}$, DAC12IR = 1, DAC12SREFx = {2, 3}. Nyquist criteria applied: $0 < f \leq 5\text{kHz}$.
 4. Measured with DAC12-generated 250Hz sine wave, 400 samples/period, $V_{PP} \sim 0.9 \cdot AV_{CC}$, $V_{DC} = AV_{CC}/2$, $V_{eREF+} = AV_{CC}$, DAC12IR = 1, DAC12SREFx = {2, 3}. Nyquist criteria applied: $0 < f \leq 50\text{kHz}$.
 5. $R_{LOAD} = 3\text{ k}\Omega$, $C_{LOAD} = 100\text{ pF}$

MSP430x15x, MSP430x16x, MSP430x161x MIXED SIGNAL MICROCONTROLLER

SLAS368A– OCTOBER 2002– REVISED MARCH 2003

electrical characteristics over recommended operating free-air temperature (unless otherwise noted)

12-bit DAC, dynamic specifications continued ($T_A = 25^\circ\text{C}$ unless otherwise noted)

3-dB bandwidth, BW _{-3dB} $V_{DC}=1.5\text{V}$, $V_{AC}=0.1\text{V}_{PP}$ (see Figure 21)	DAC12AMPx = {2, 3, 4}, DAC12SREFx = 2, DAC12IR = 1, DAC12_xDAT = 800h	2.2V/3V	40.0	kHz
	DAC12AMPx = {5, 6}, DAC12SREFx = 2, DAC12IR = 1, DAC12_xDAT = 800h	2.2V/3V	180.0	
	DAC12AMPx = 7, DAC12SREFx = 2, DAC12IR = 1, DAC12_xDAT = 800h	2.2V/3V	584.0	
Channel to channel crosstalk (see Note 1 and Figure 22)	DAC12_0DAT = 800h, No Load, DAC12_1DAT = 80h \leftrightarrow F7Fh, $R_{Load} = 3\text{k}\Omega$ $f_{DAC12_1OUT} = 10\text{kHz}$ @ 50/50 duty cycle	2.2V/3V	-80	dB
	DAC12_0DAT = 80h \leftrightarrow F7Fh, $R_{Load} = 3\text{k}\Omega$, DAC12_1DAT = 800h, No Load $f_{DAC12_0OUT} = 10\text{kHz}$ @ 50/50 duty cycle	2.2V/3V	-80	

NOTES: 1. $R_{LOAD} = 3\text{ k}\Omega$, $C_{LOAD} = 100\text{ pF}$

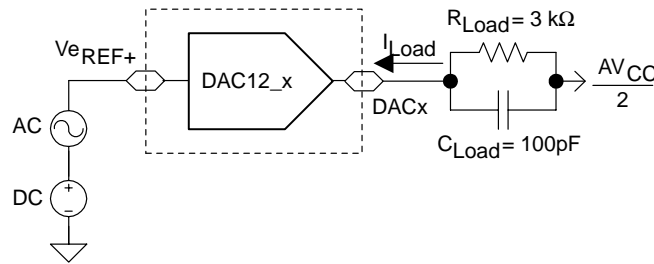

Figure 21. Test Conditions for 3-dB Bandwidth Specification

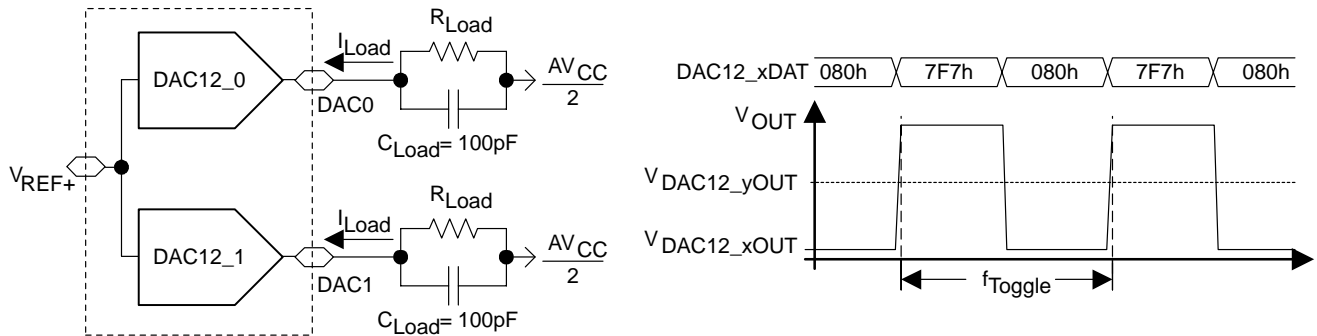

Figure 22. Crosstalk Test Conditions

JTAG, program memory and fuse

PARAMETER		TEST CONDITIONS	V _{CC}	MIN	NOM	MAX	UNIT	
f _(TCK)	JTAG/Test (see Note 4)	TCK frequency	2.2 V	DC		5	MHz	
			3 V	DC		10		
		Pullup resistors on TMS, TCK, TDI (see Note 1)	2.2 V/ 3V	25	60	90	kΩ	
V _{CC(FB)}	JTAG/fuse (see Note 2)	Supply voltage during fuse-blow condition, T _(A) = 25°C		2.5			V	
V _{FB}		Fuse-blow voltage, F versions (see Note 3)		6.0		7.0	V	
I _{FB}		Supply current on TDI with fuse blown					100	mA
		Time to blow the fuse					1	ms
I _(DD-PGM)	F-versions only (see Note 4)	Current from DV _{CC} when programming is active	2.7 V/3.6 V		3	5	mA	
I _(DD-Erase)		Current from DV _{CC} when erase is active	2.7 V/3.6 V		3	5	mA	
t _(retention)	F-versions only	Write/erase cycles		10 ⁴	10 ⁵		cycles	
		Data retention T _J = 25°C		100			years	

- NOTES: 1. TMS, TDI, and TCK pullup resistors are implemented in all F versions.
 2. Once the fuse is blown, no further access to the MSP430 JTAG/test feature is possible. The JTAG block is switched to bypass mode.
 3. The supply voltage to blow the fuse is applied to the TDI pin.
 4. f_(TCK) may be restricted to meet the timing requirements of the module selected. Duration of the program/erase cycle is determined by f_(FTG) applied to the flash timing controller. It can be calculated as follows:
 $t(\text{word write}) = 35 \times 1/f(\text{FTG})$
 $t(\text{block write, byte 0}) = 30 \times 1/f(\text{FTG})$
 $t(\text{block write, bytes 1–63}) = 20 \times 1/f(\text{FTG})$
 $t(\text{block write end sequence}) = 6 \times 1/f(\text{FTG})$
 $t(\text{mass erase}) = 5297 \times 1/f(\text{FTG})$
 $t(\text{segment erase}) = 4819 \times 1/f(\text{FTG})$

MSP430x15x, MSP430x16x, MSP430x161x MIXED SIGNAL MICROCONTROLLER

SLAS368A– OCTOBER 2002– REVISED MARCH 2003

input/output schematic

port P1, P1.0 to P1.7, input/output with Schmitt-trigger

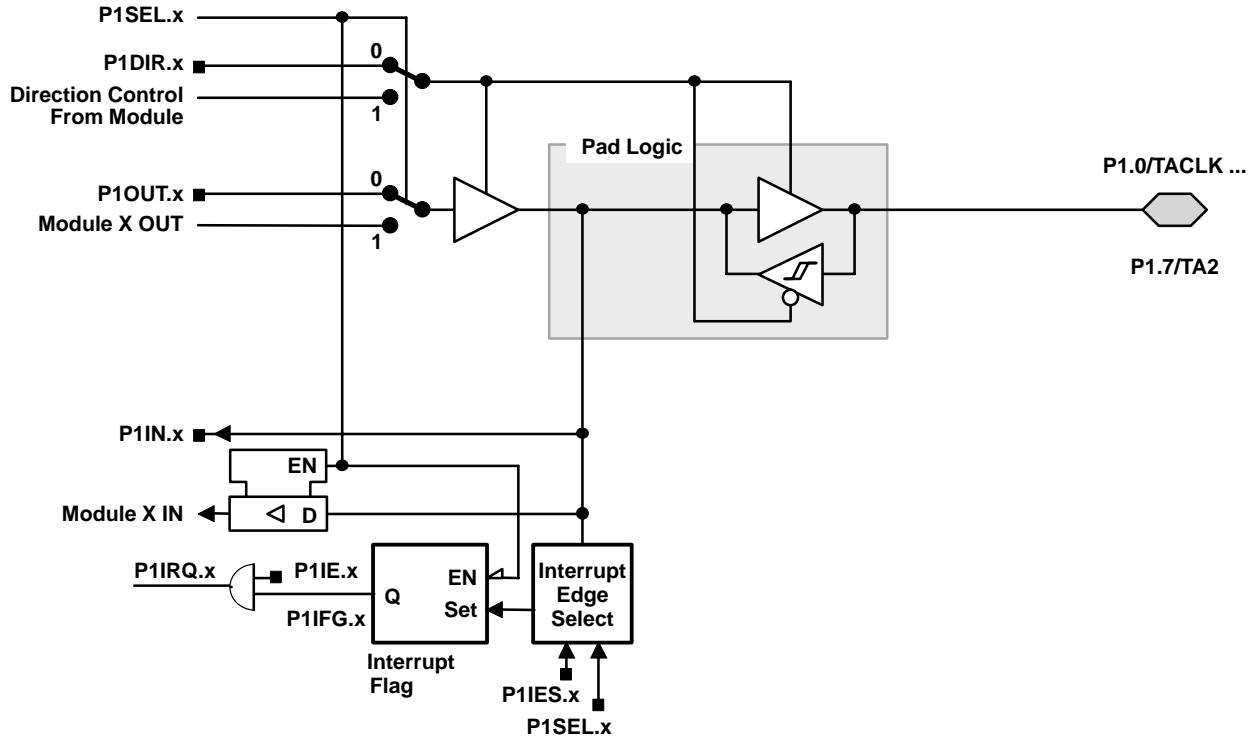

PRODUCT PREVIEW

PnSel.x	PnDIR.x	Dir. CONTROL FROM MODULE	PnOUT.x	MODULE X OUT	PnIN.x	MODULE X IN	PnIE.x	PnIFG.x	PnIES.x
P1Sel.0	P1DIR.0	P1DIR.0	P1OUT.0	DV _{SS}	P1IN.0	TACLK†	P1IE.0	P1IFG.0	P1IES.0
P1Sel.1	P1DIR.1	P1DIR.1	P1OUT.1	Out0 signal†	P1IN.1	CC10A†	P1IE.1	P1IFG.1	P1IES.1
P1Sel.2	P1DIR.2	P1DIR.2	P1OUT.2	Out1 signal†	P1IN.2	CC11A†	P1IE.2	P1IFG.2	P1IES.2
P1Sel.3	P1DIR.3	P1DIR.3	P1OUT.3	Out2 signal†	P1IN.3	CC12A†	P1IE.3	P1IFG.3	P1IES.3
P1Sel.4	P1DIR.4	P1DIR.4	P1OUT.4	SMCLK	P1IN.4	unused	P1IE.4	P1IFG.4	P1IES.4
P1Sel.5	P1DIR.5	P1DIR.5	P1OUT.5	Out0 signal†	P1IN.5	unused	P1IE.5	P1IFG.5	P1IES.5
P1Sel.6	P1DIR.6	P1DIR.6	P1OUT.6	Out1 signal†	P1IN.6	unused	P1IE.6	P1IFG.6	P1IES.6
P1Sel.7	P1DIR.7	P1DIR.7	P1OUT.7	Out2 signal†	P1IN.7	unused	P1IE.7	P1IFG.7	P1IES.7

† Signal from or to Timer_A

input/output schematic (continued)

port P2, P2.0 to P2.2, P2.6, and P2.7 input/output with Schmitt-trigger

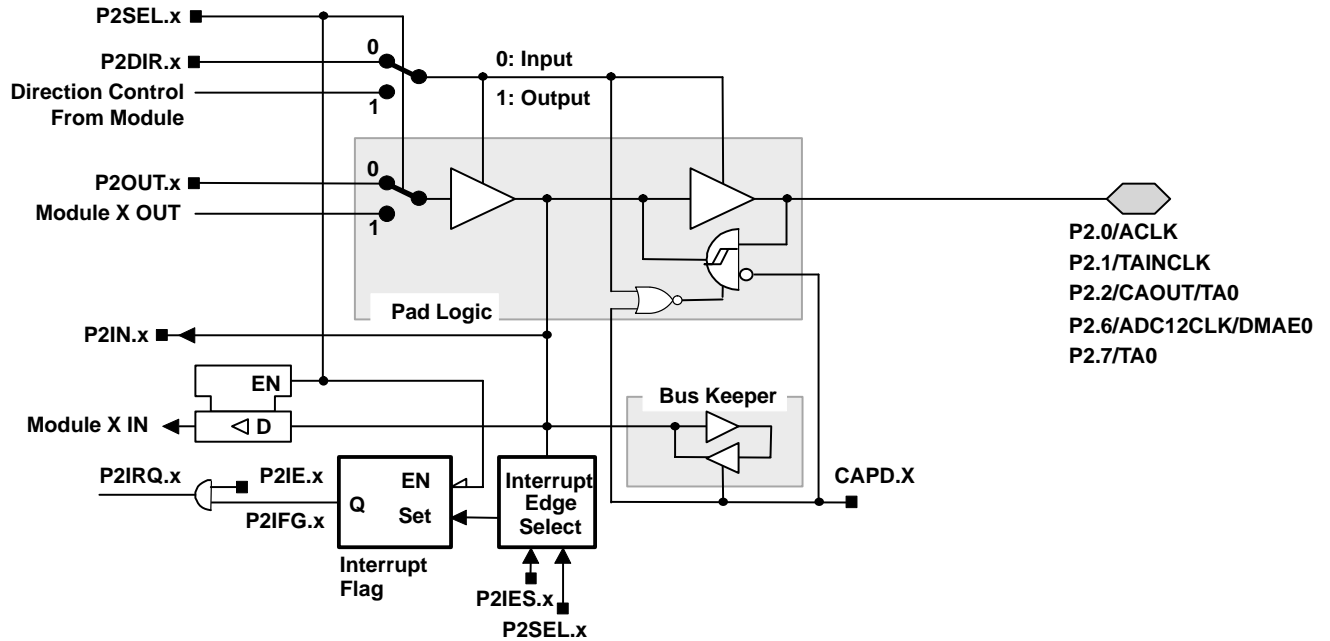

x: Bit Identifier 0 to 2, 6, and 7 for Port P2

PnSel.x	PnDIR.x	Dir. CONTROL FROM MODULE	PnOUT.x	MODULE X OUT	PnIN.x	MODULE X IN	PnIE.x	PnIFG.x	PnIES.x
P2Sel.0	P2DIR.0	P2DIR.0	P2OUT.0	ACLK	P2IN.0	unused	P2IE.0	P2IFG.0	P2IES.0
P2Sel.1	P2DIR.1	P2DIR.1	P2OUT.1	DVSS	P2IN.1	INCLK [‡]	P2IE.1	P2IFG.1	P2IES.1
P2Sel.2	P2DIR.2	P2DIR.2	P2OUT.2	CAOUT [†]	P2IN.2	CCI0B [‡]	P2IE.2	P2IFG.2	P2IES.2
P2Sel.6	P2DIR.6	P2DIR.6	P2OUT.6	ADC12CLK [¶]	P2IN.6	DMAE0 [#]	P2IE.6	P2IFG.6	P2IES.6
P2Sel.7	P2DIR.7	P2DIR.7	P2OUT.7	Out0 signal [§]	P2IN.7	unused	P2IE.7	P2IFG.7	P2IES.7

[†] Signal from Comparator_A

[‡] Signal to Timer_A

[§] Signal from Timer_A

[¶] ADC12CLK signal is output of the 12-bit ADC module

[#] Signal to DMA, channel 0, 1 and 2

PRODUCT PREVIEW

MSP430x15x, MSP430x16x, MSP430x161x MIXED SIGNAL MICROCONTROLLER

SLAS368A– OCTOBER 2002– REVISED MARCH 2003

input/output schematic (continued)

port P2, P2.3 to P2.4, input/output with Schmitt-trigger

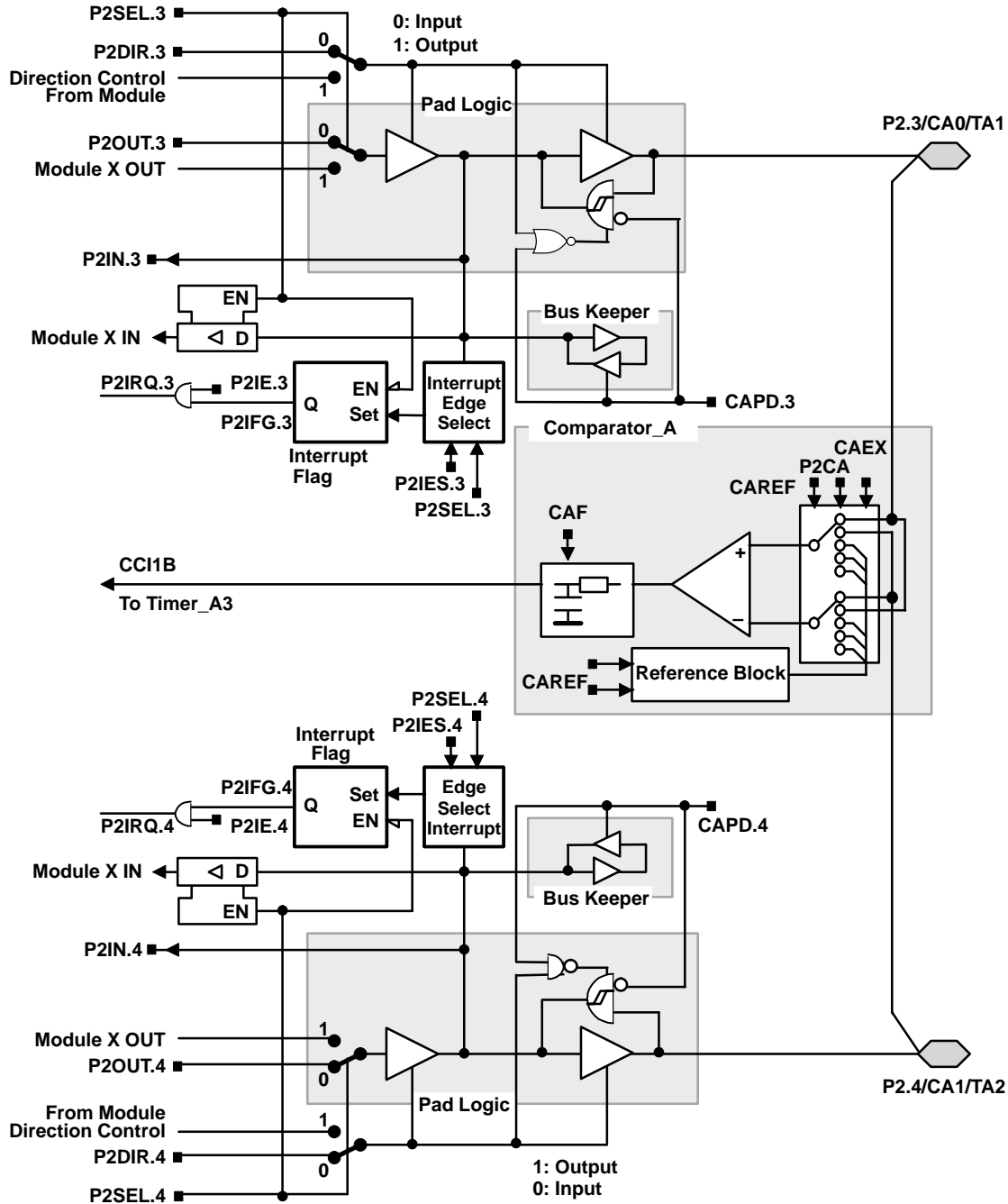

PnSel.x	PnDIR.x	DIRECTION CONTROL FROM MODULE	PnOUT.x	MODULE X OUT	PnIN.x	MODULE X IN	PnIE.x	PnIFG.x	PnIES.x
P2Sel.3	P2DIR.3	P2DIR.3	P2OUT.3	Out1 signal†	P2IN.3	unused	P2IE.3	P2IFG.3	P2IES.3
P2Sel.4	P2DIR.4	P2DIR.4	P2OUT.4	Out2 signal†	P2IN.4	unused	P2IE.4	P2IFG.4	P2IES.4

† Signal from Timer_A

PRODUCT PREVIEW



input/output schematic (continued)

port P2, P2.5, input/output with Schmitt-trigger and R_{OSC} function for the basic clock module

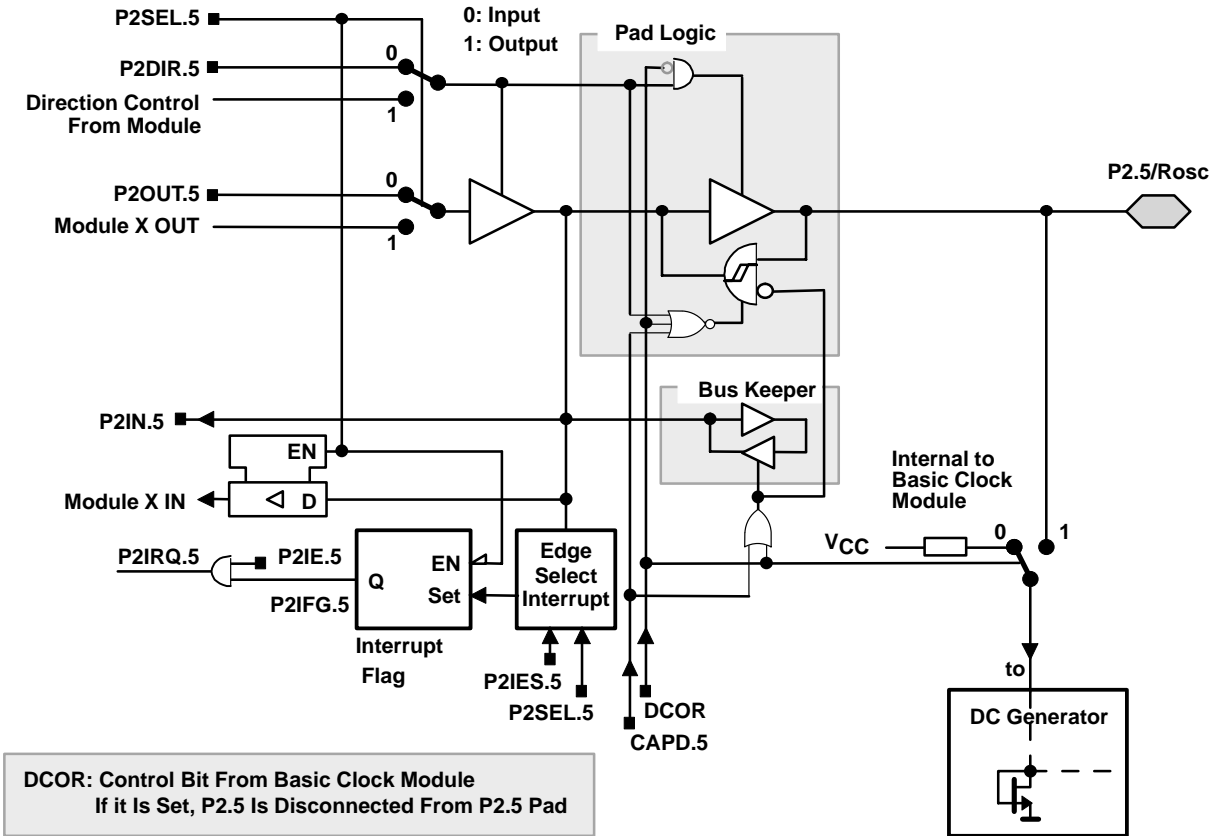

PnSel.x	PnDIR.x	DIRECTION CONTROL FROM MODULE	PnOUT.x	MODULE X OUT	PnIN.x	MODULE X IN	PnIE.x	PnIFG.x	PnIES.x
P2Sel.5	P2DIR.5	P2DIR.5	P2OUT.5	DV _{SS}	P2IN.5	unused	P2IE.5	P2IFG.5	P2IES.5

PRODUCT PREVIEW

MSP430x15x, MSP430x16x, MSP430x161x MIXED SIGNAL MICROCONTROLLER

SLAS368A– OCTOBER 2002– REVISED MARCH 2003

input/output schematic (continued)

port P3, P3.0 and P3.4 to P3.7, input/output with Schmitt-trigger

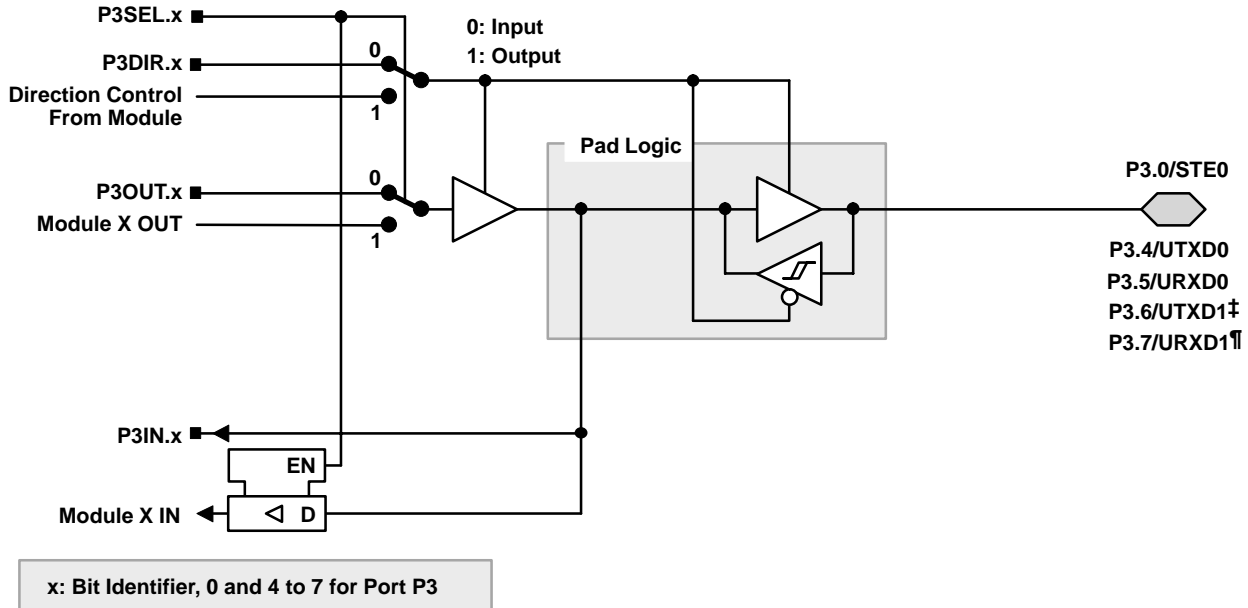

PnSel.x	PnDIR.x	DIRECTION CONTROL FROM MODULE	PnOUT.x	MODULE X OUT	PnIN.x	MODULE X IN
P3Sel.0	P3DIR.0	DV _{SS}	P3OUT.0	DV _{SS}	P3IN.0	STE0
P3Sel.4	P3DIR.4	DV _{CC}	P3OUT.4	UTXD0†	P3IN.4	Unused
P3Sel.5	P3DIR.5	DV _{SS}	P3OUT.5	DV _{SS}	P3IN.5	URXD0§
P3Sel.6	P3DIR.6	DV _{CC}	P3OUT.6	UTXD1‡	P3IN.6	Unused
P3Sel.7	P3DIR.7	DV _{SS}	P3OUT.7	DV _{SS}	P3IN.7	URXD1†

† Output from USART0 module

‡ Output from USART1 module

§ Input to USART0 module

† Input to USART1 module

port P3, P3.1, input/output with Schmitt-trigger

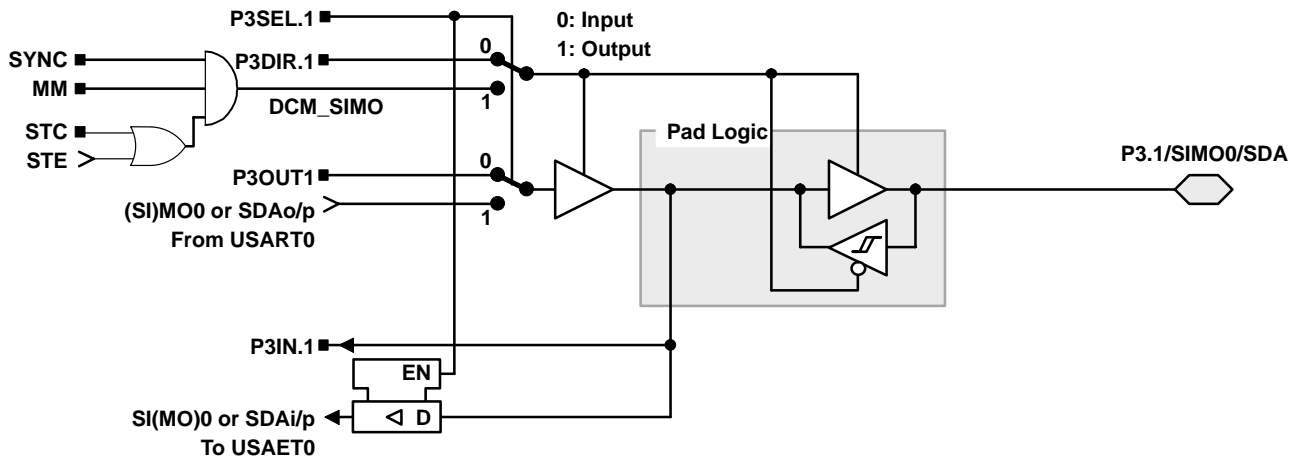

PRODUCT PREVIEW

input/output schematic (continued)

port P3, P3.2, input/output with Schmitt-trigger

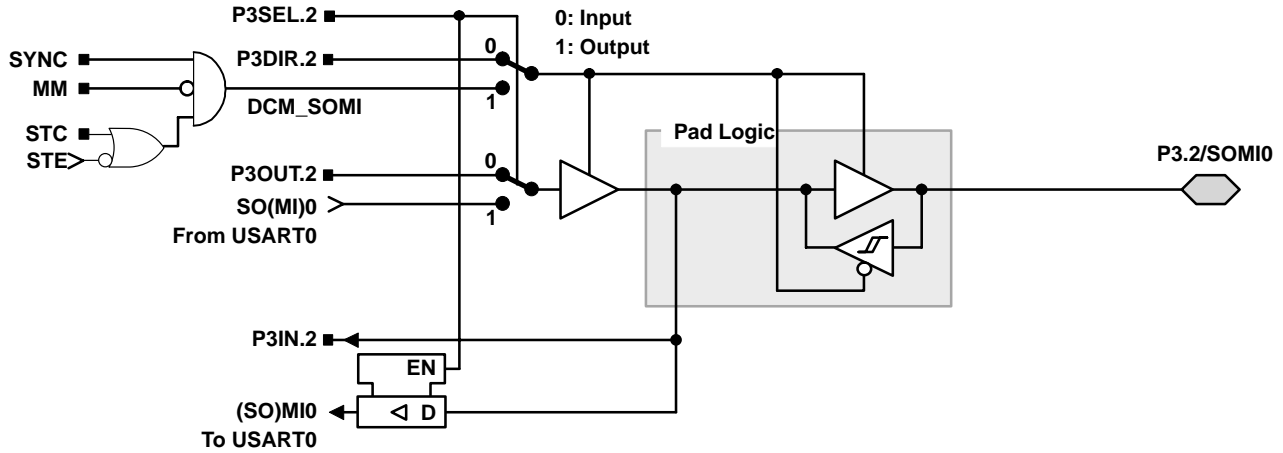

port P3, P3.3, input/output with Schmitt-trigger

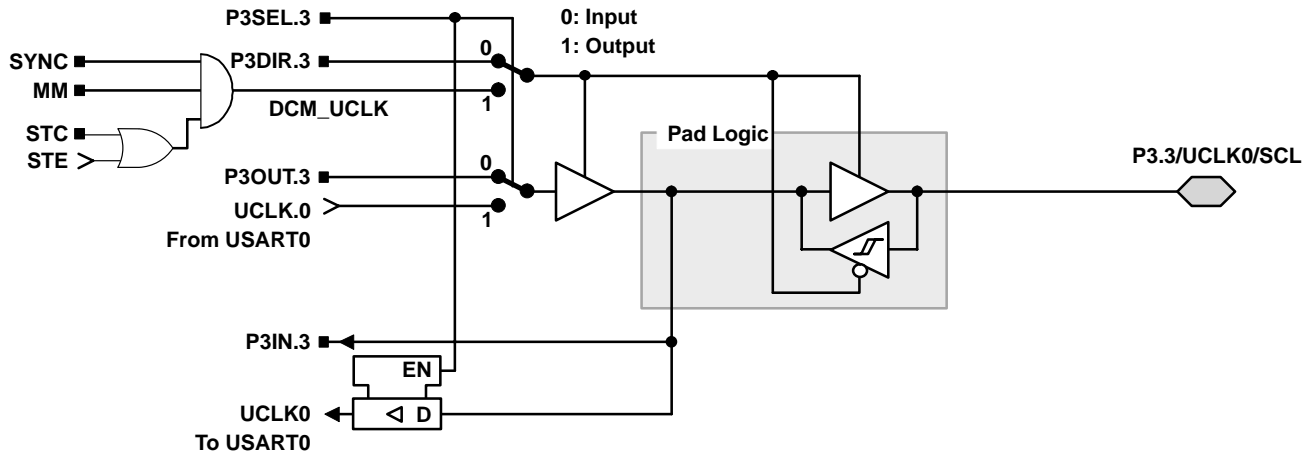

- NOTE: UART mode: The UART clock can only be an input. If UART mode and UART function are selected, the P3.3/UCLK0 is always an input.
- SPI, slave mode: The clock applied to UCLK0 is used to shift data in and out.
- SPI, master mode: The clock to shift data in and out is supplied to connected devices on pin P3.3/UCLK0 (in slave mode).
- I²C, slave mode: The clock applied to SCL is used to shift data in and out. The frequency of the clock source of the module must be ≥ 10 times the frequency of the SCL clock.
- I²C, master mode: To shift data in and out, the clock is supplied via the SCL terminal to all I²C slaves. The frequency of the clock source of the module must be ≥ 10 times the frequency of the SCL clock.

MSP430x15x, MSP430x16x, MSP430x161x MIXED SIGNAL MICROCONTROLLER

SLAS368A– OCTOBER 2002– REVISED MARCH 2003

input/output schematic (continued)

port P4, P4.0 to P4.6, input/output with Schmitt-trigger

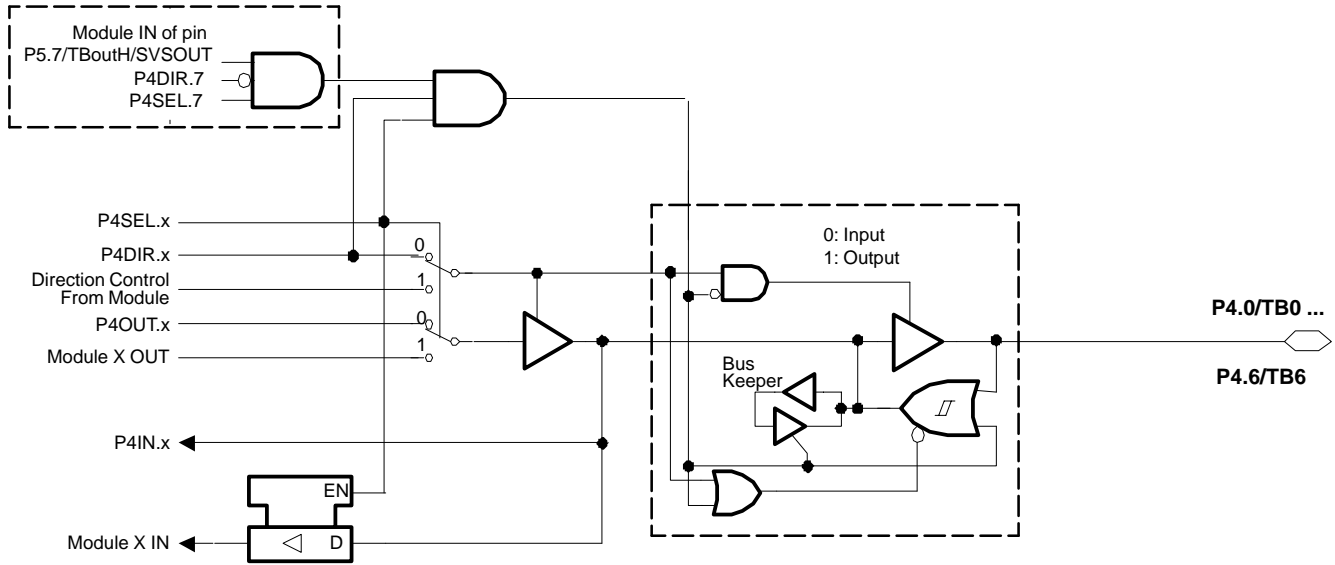

x: Bit Identifier, 0 to 6 for Port P4

PnSel.x	PnDIR.x	DIRECTION CONTROL FROM MODULE	PnOUT.x	MODULE X OUT	PnIN.x	MODULE X IN
P4Sel.0	P4DIR.0	P4DIR.0	P4OUT.0	Out0 signal [†]	P4IN.0	CCI0A / CCI0B [‡]
P4Sel.1	P4DIR.1	P4DIR.1	P4OUT.1	Out1 signal [†]	P4IN.1	CCI1A / CCI1B [‡]
P4Sel.2	P4DIR.2	P4DIR.2	P4OUT.2	Out2 signal [†]	P4IN.2	CCI2A / CCI2B [‡]
P4Sel.3	P4DIR.3	P4DIR.3	P4OUT.3	Out3 signal [†]	P4IN.3	CCI3A / CCI3B [‡]
P4Sel.4	P4DIR.4	P4DIR.4	P4OUT.4	Out4 signal [†]	P4IN.4	CCI4A / CCI4B [‡]
P4Sel.5	P4DIR.5	P4DIR.5	P4OUT.5	Out5 signal [†]	P4IN.5	CCI5A / CCI5B [‡]
P4Sel.6	P4DIR.6	P4DIR.6	P4OUT.6	Out6 signal [†]	P4IN.6	CCI6A

[†] Signal from Timer_B

[‡] Signal to Timer_B

PRODUCT PREVIEW

input/output schematic (continued)

port P4, P4.7, input/output with Schmitt-trigger

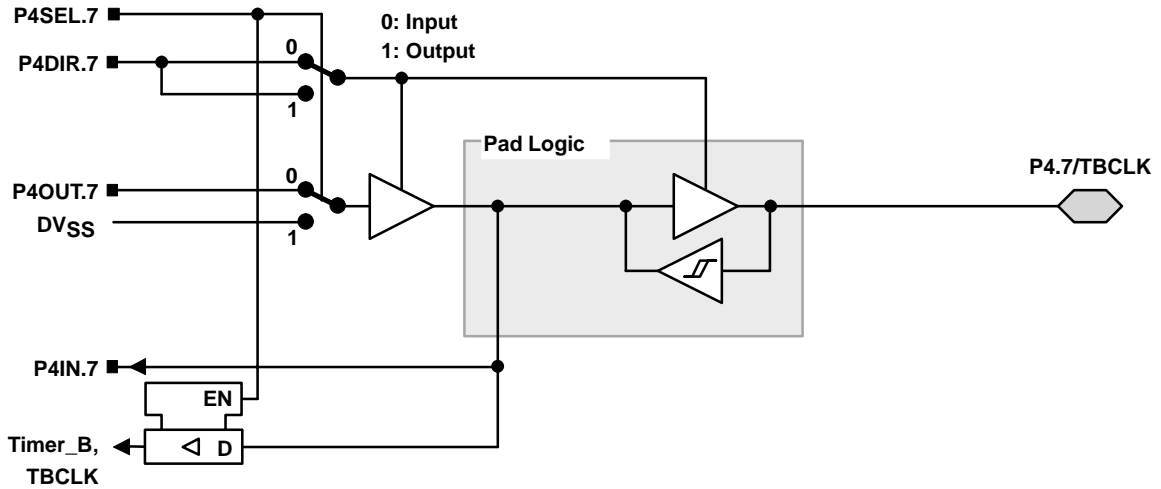

port P5, P5.0 and P5.4 to P5.7, input/output with Schmitt-trigger

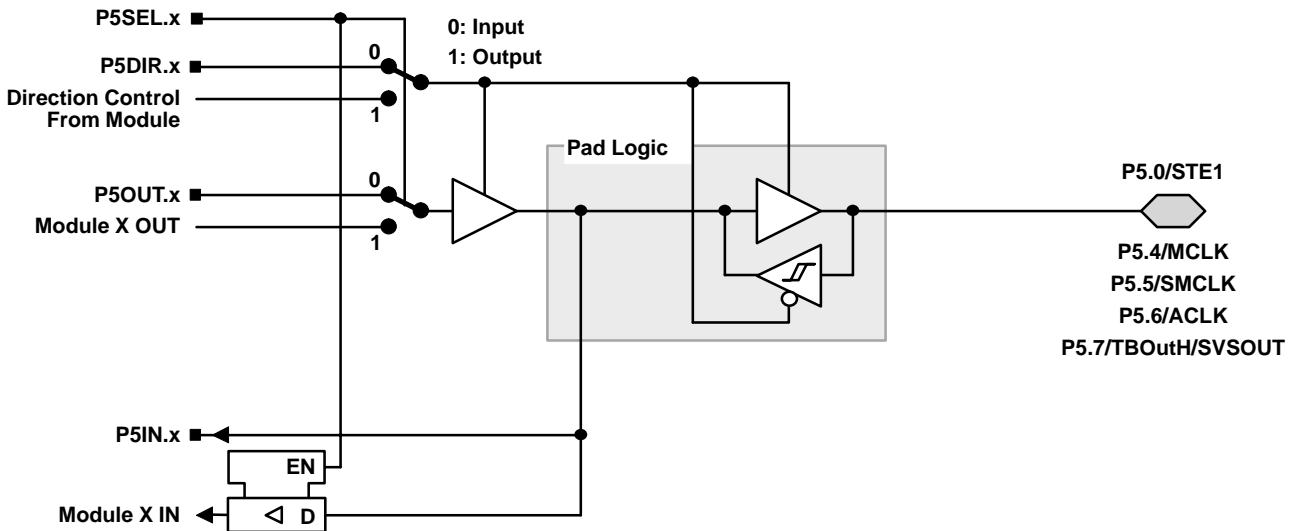

x: Bit Identifier, 0 and 4 to 7 for Port P5

PnSel.x	PnDIR.x	Dir. CONTROL FROM MODULE	PnOUT.x	MODULE X OUT	PnIN.x	MODULE X IN
P5Sel.0	P5DIR.0	DV _{SS}	P5OUT.0	DV _{SS}	P5IN.0	STE.1
P5Sel.4	P5DIR.4	DV _{CC}	P5OUT.4	MCLK	P5IN.4	unused
P5Sel.5	P5DIR.5	DV _{CC}	P5OUT.5	SMCLK	P5IN.5	unused
P5Sel.6	P5DIR.6	DV _{CC}	P5OUT.6	ACLK	P5IN.6	unused
P5Sel.7	P5DIR.7	DV _{SS}	P5OUT.7	SVSOUT	P5IN.7	TBOutHiZ

NOTE: TBOutHiZ signal is used by port module P4, pins P4.0 to P4.6. The function of TBOutHiZ is mainly useful when used with Timer_B7.

PRODUCT PREVIEW

MSP430x15x, MSP430x16x, MSP430x161x MIXED SIGNAL MICROCONTROLLER

SLAS368A– OCTOBER 2002– REVISED MARCH 2003

input/output schematic (continued)

port P5, P5.1, input/output with Schmitt-trigger

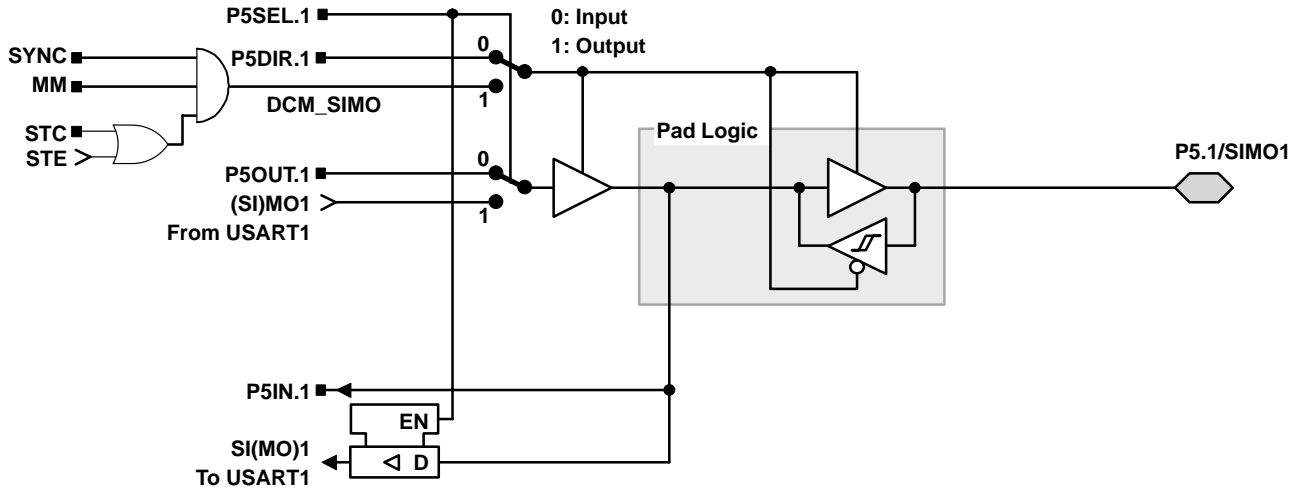

port P5, P5.2, input/output with Schmitt-trigger

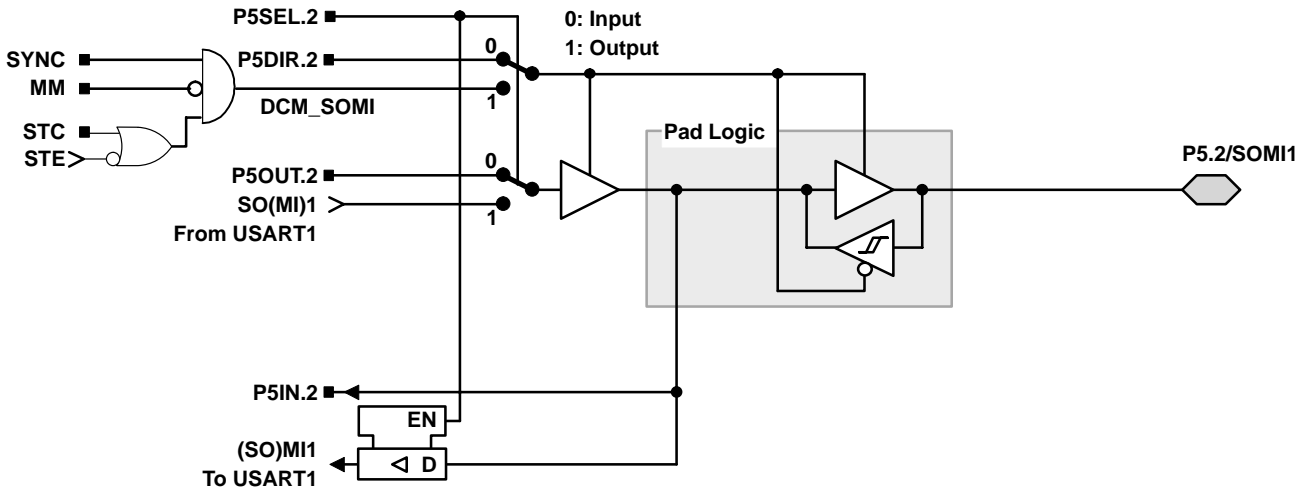

PRODUCT PREVIEW

input/output schematic (continued)

port P5, P5.3, input/output with Schmitt-trigger

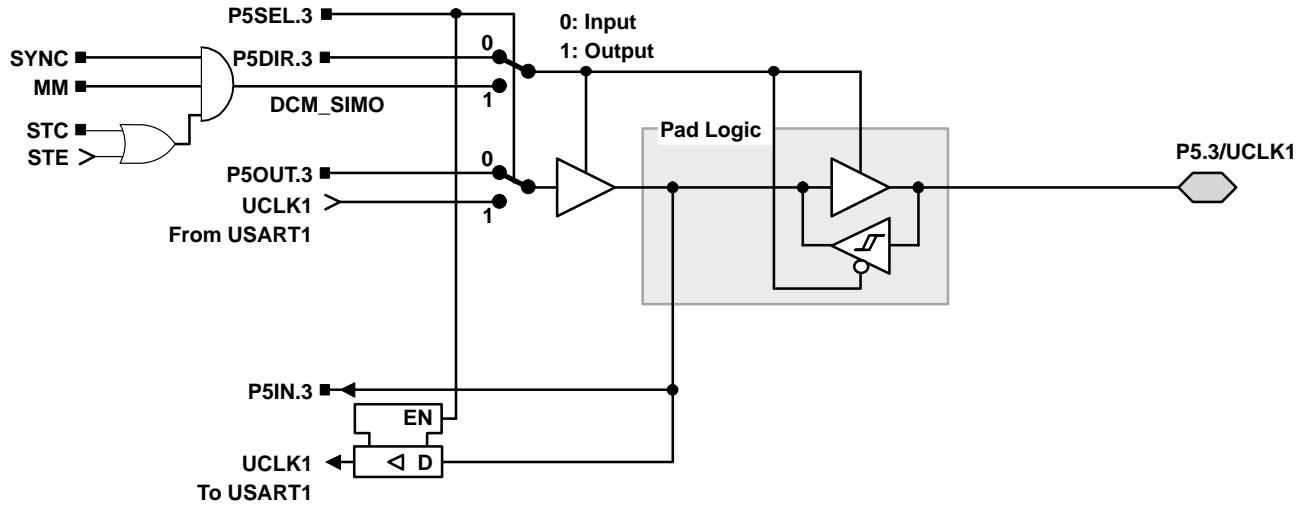

NOTE: UART mode: The UART clock can only be an input. If UART mode and UART function are selected, the P5.3/UCLK1 direction is always input.
 SPI, slave mode: The clock applied to UCLK1 is used to shift data in and out.
 SPI, master mode: The clock to shift data in and out is supplied to connected devices on pin P5.3/UCLK1 (in slave mode).

PRODUCT PREVIEW

MSP430x15x, MSP430x16x, MSP430x161x MIXED SIGNAL MICROCONTROLLER

SLAS368A– OCTOBER 2002– REVISED MARCH 2003

input/output schematic (continued)

port P6, P6.0 to P6.5, input/output with Schmitt-trigger

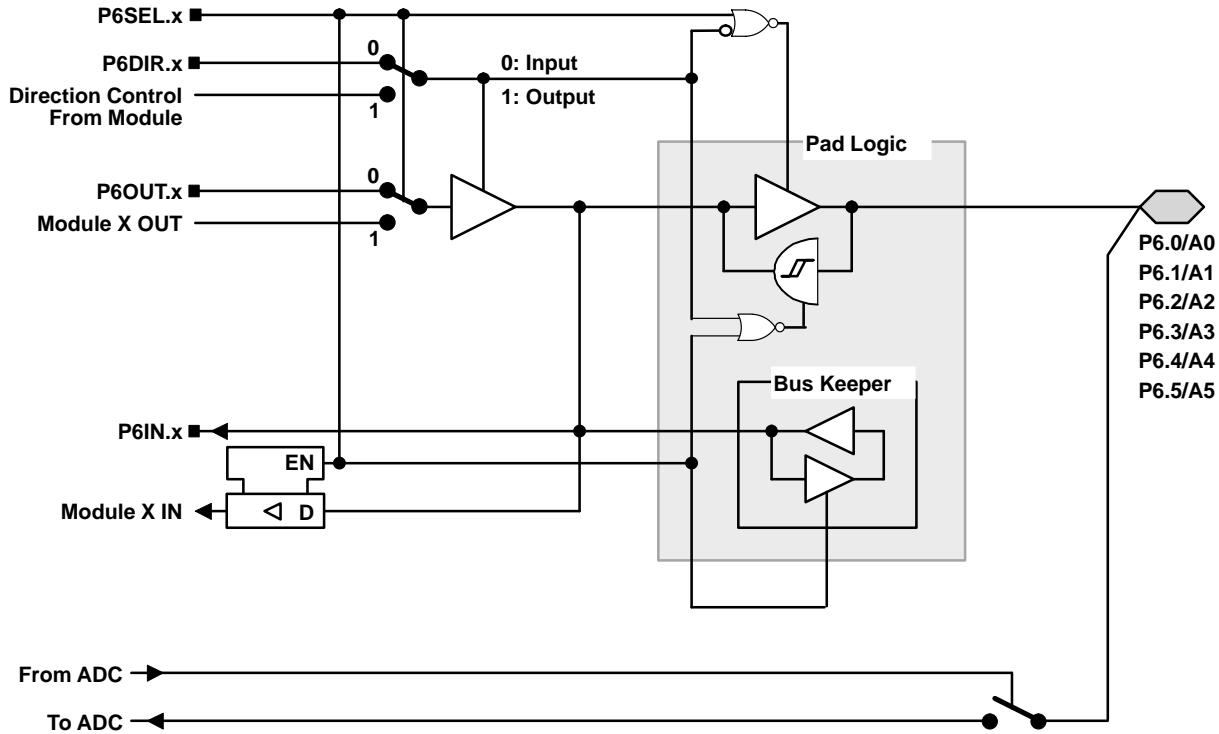

x: Bit Identifier, 0 to 5 for Port P6

NOTE: Analog signals applied to digital gates can cause current flow from the positive to the negative terminal. The throughput current flows if the analog signal is in the range of transitions 0→1 or 1←0. The value of the throughput current depends on the driving capability of the gate. For MSP430, it is approximately 100 μA.

Use P6SEL.x=1 to prevent throughput current. P6SEL.x should be set, even if the signal at the pin is not being used by the ADC12.

PnSel.x	PnDIR.x	DIR. CONTROL FROM MODULE	PnOUT.x	MODULE X OUT	PnIN.x	MODULE X IN
P6Sel.0	P6DIR.0	P6DIR.0	P6OUT.0	DV _{SS}	P6IN.0	unused
P6Sel.1	P6DIR.1	P6DIR.1	P6OUT.1	DV _{SS}	P6IN.1	unused
P6Sel.2	P6DIR.2	P6DIR.2	P6OUT.2	DV _{SS}	P6IN.2	unused
P6Sel.3	P6DIR.3	P6DIR.3	P6OUT.3	DV _{SS}	P6IN.3	unused
P6Sel.4	P6DIR.4	P6DIR.4	P6OUT.4	DV _{SS}	P6IN.4	unused
P6Sel.5	P6DIR.5	P6DIR.5	P6OUT.5	DV _{SS}	P6IN.5	unused

NOTE: The signal at pins P6.x/Ax is used by the 12-bit ADC module.

PRODUCT PREVIEW

input/output schematic (continued)

port P6, P6.6, input/output with Schmitt-trigger

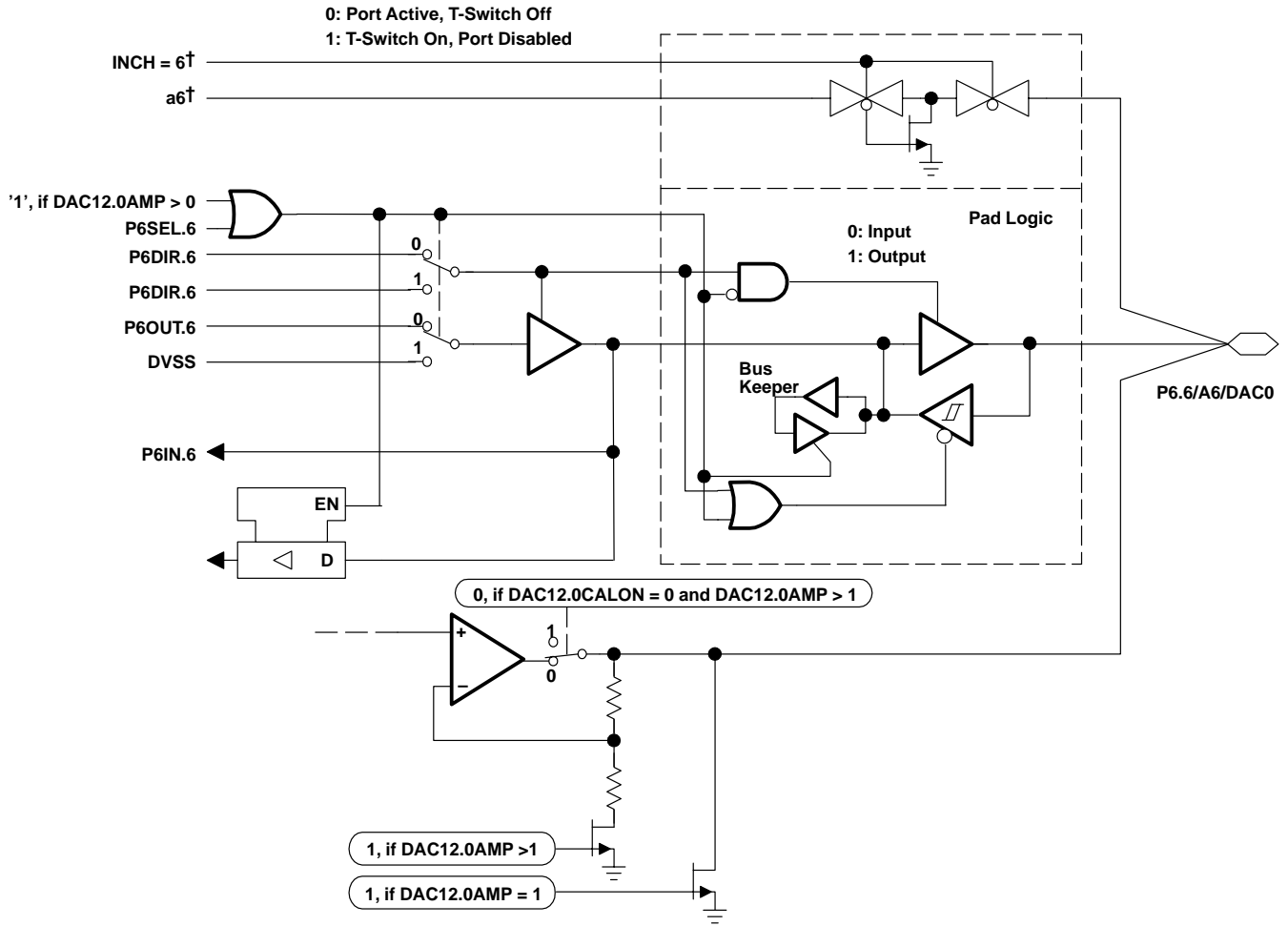

PRODUCT PREVIEW

MSP430x15x, MSP430x16x, MSP430x161x MIXED SIGNAL MICROCONTROLLER

SLAS368A– OCTOBER 2002– REVISED MARCH 2003

input/output schematic (continued)

port P6, P6.7, input/output with Schmitt-trigger

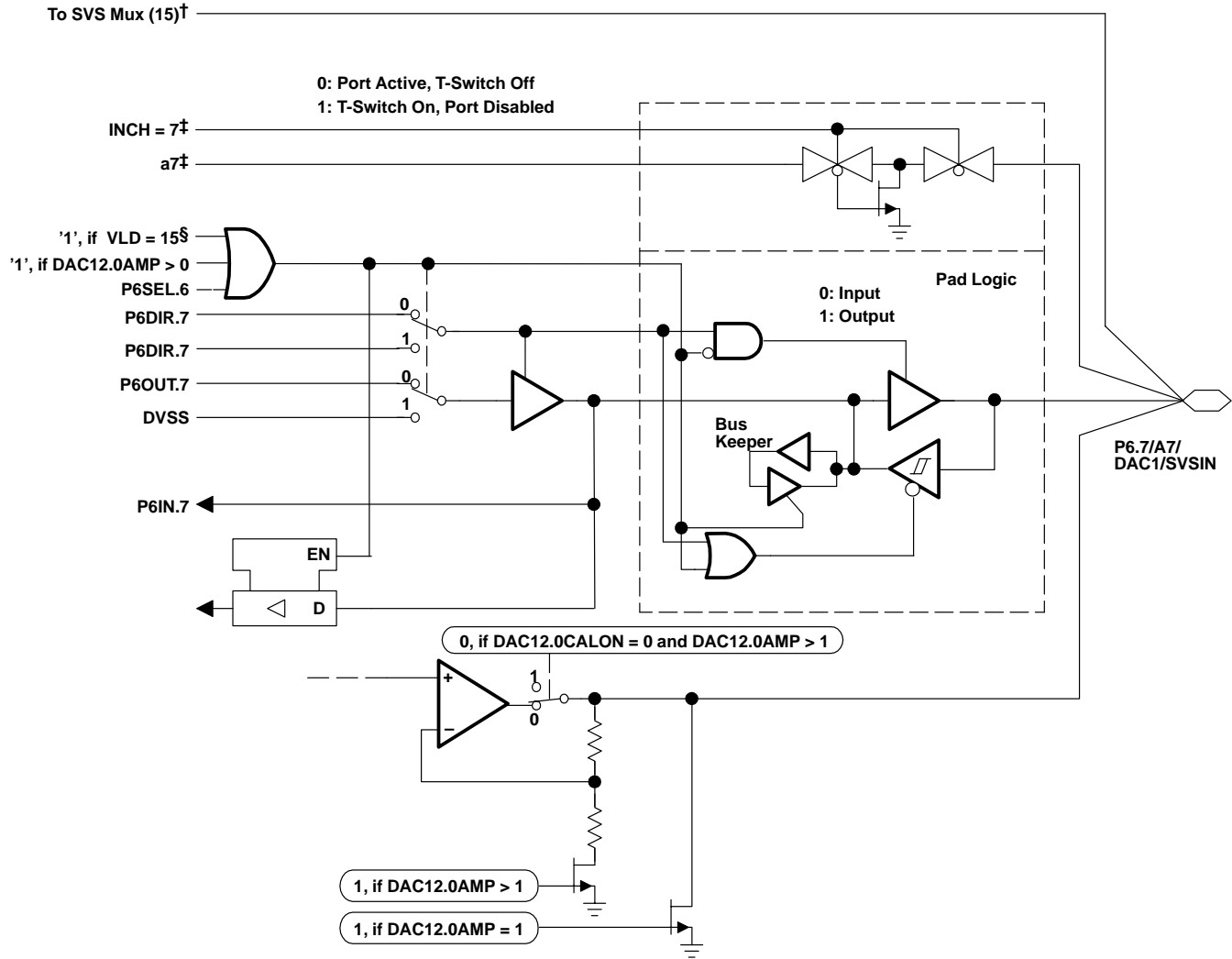

†Signal to SVS Block, Selected if VLD = 15

‡Signal From or To ADC12

§VLD Control Bits are Located in SVS

PRODUCT PREVIEW

input/output schematic (continued)

JTAG pins TMS, TCK, TDI, TDO/TDI, input/output with Schmitt-trigger

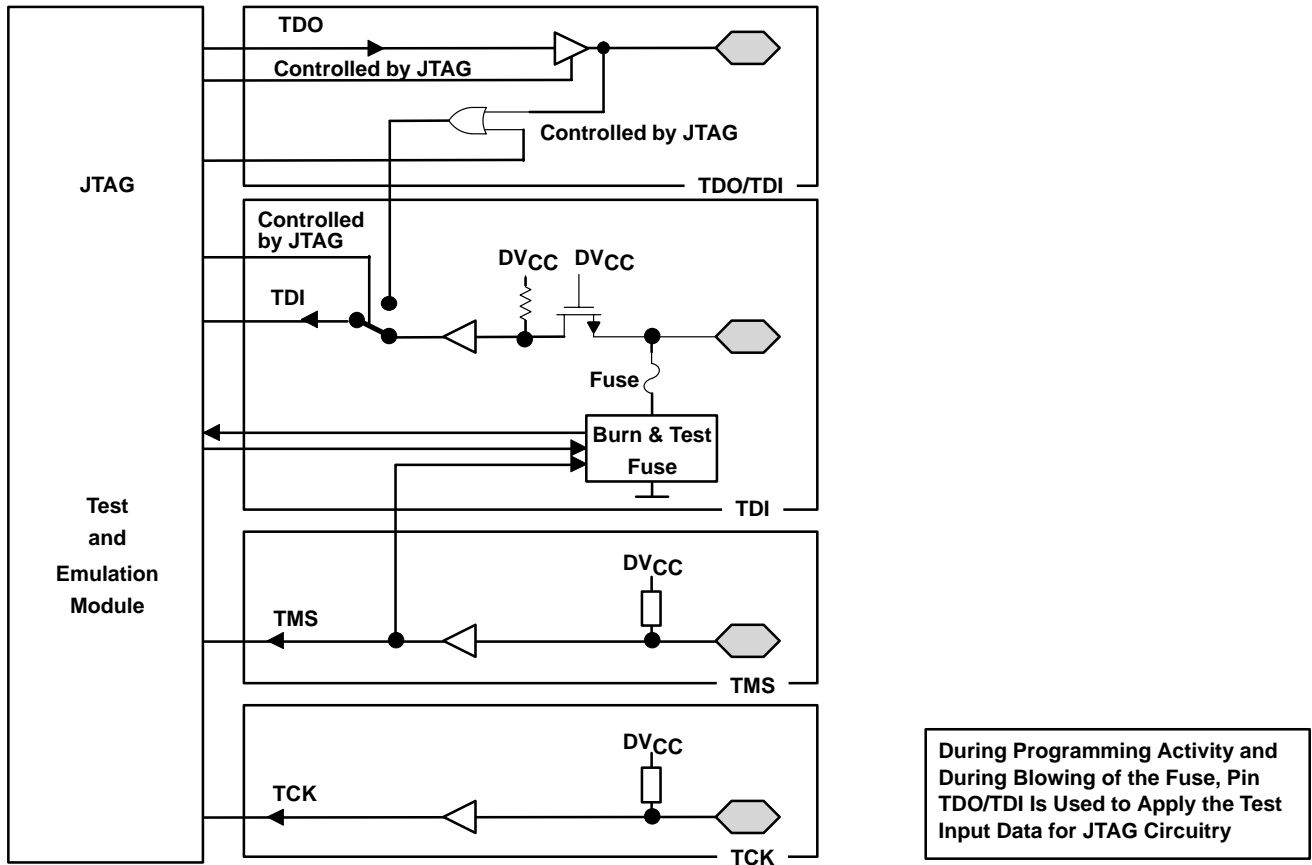

JTAG fuse check mode

MSP430 devices that have the fuse on the TDI terminal have a fuse check mode that tests the continuity of the fuse the first time the JTAG port is accessed after a power-on reset (POR). When activated, a fuse check current, I_{TF} , of 1 mA at 3 V, 2.5 mA at 5 V can flow from the TDI pin to ground if the fuse is not burned. Care must be taken to avoid accidentally activating the fuse check mode and increasing overall system power consumption.

Activation of the fuse check mode occurs with the first negative edge on the TMS pin after power up or if the TMS is being held low during power up. The second positive edge on the TMS pin deactivates the fuse check mode. After deactivation, the fuse check mode remains inactive until another POR occurs. After each POR the fuse check mode has the potential to be activated.

The fuse check current will only flow when the fuse check mode is active and the TMS pin is in a low state (see Figure 23). Therefore, the additional current flow can be prevented by holding the TMS pin high (default condition).

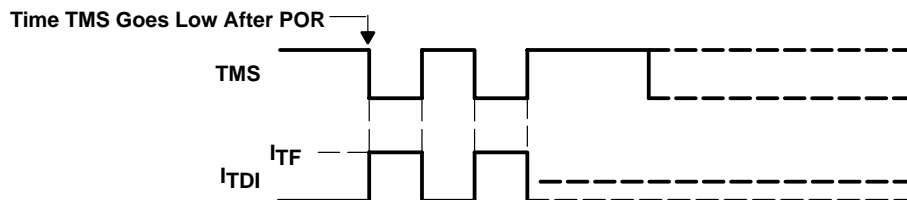

Figure 23. Fuse Check Mode Current, MSP430x15x/16x/161x

MSP430x15x, MSP430x16x, MSP430x161x MIXED SIGNAL MICROCONTROLLER

SLAS368A– OCTOBER 2002– REVISED MARCH 2003

MECHANICAL DATA

PM (S-PQFP-G64)

PLASTIC QUAD FLATPACK

PRODUCT PREVIEW

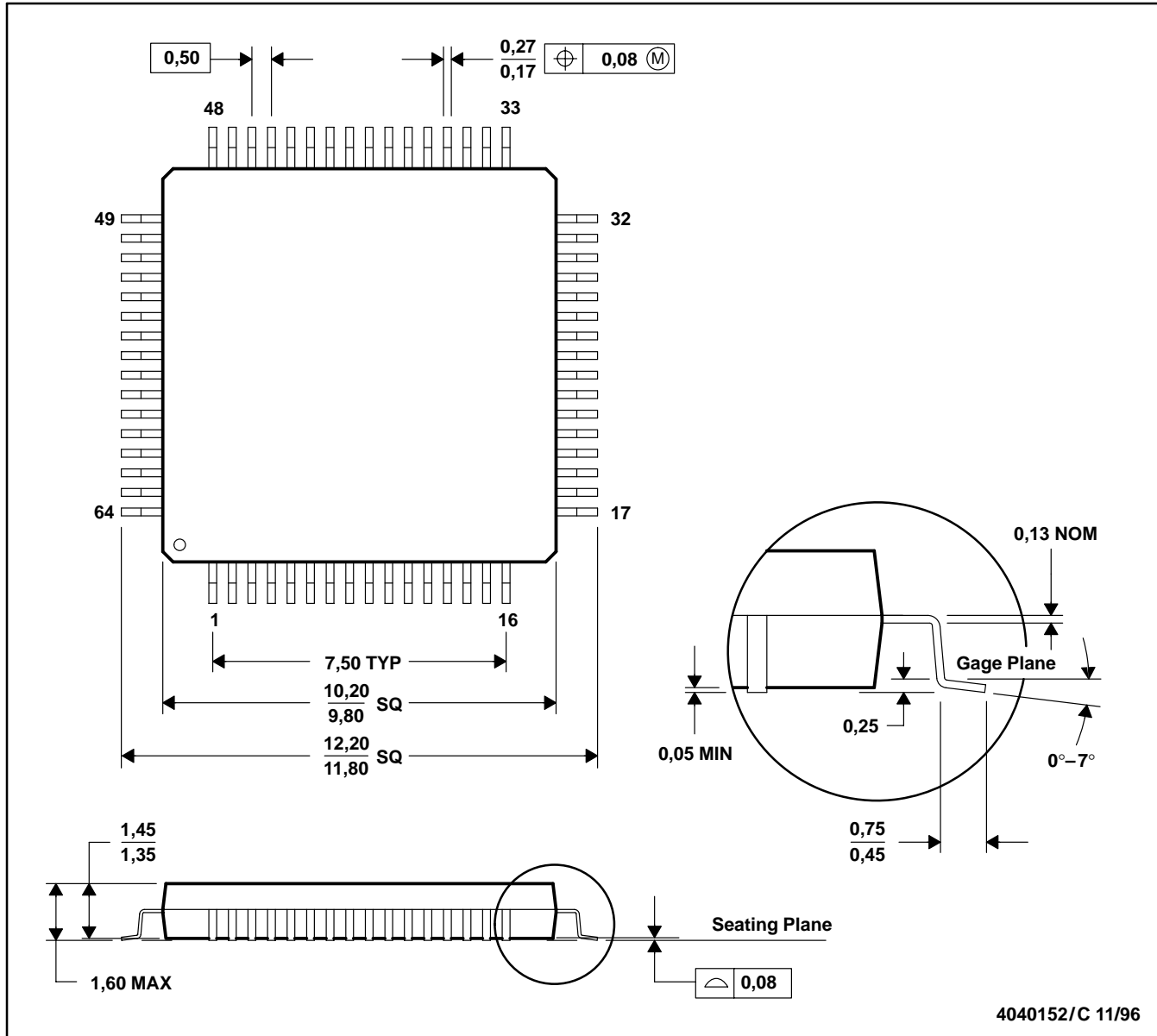

- NOTES: A. All linear dimensions are in millimeters.
 B. This drawing is subject to change without notice.
 C. Falls within JEDEC MS-026
 D. May also be thermally enhanced plastic with leads connected to the die pads.

IMPORTANT NOTICE

Texas Instruments Incorporated and its subsidiaries (TI) reserve the right to make corrections, modifications, enhancements, improvements, and other changes to its products and services at any time and to discontinue any product or service without notice. Customers should obtain the latest relevant information before placing orders and should verify that such information is current and complete. All products are sold subject to TI's terms and conditions of sale supplied at the time of order acknowledgment.

TI warrants performance of its hardware products to the specifications applicable at the time of sale in accordance with TI's standard warranty. Testing and other quality control techniques are used to the extent TI deems necessary to support this warranty. Except where mandated by government requirements, testing of all parameters of each product is not necessarily performed.

TI assumes no liability for applications assistance or customer product design. Customers are responsible for their products and applications using TI components. To minimize the risks associated with customer products and applications, customers should provide adequate design and operating safeguards.

TI does not warrant or represent that any license, either express or implied, is granted under any TI patent right, copyright, mask work right, or other TI intellectual property right relating to any combination, machine, or process in which TI products or services are used. Information published by TI regarding third-party products or services does not constitute a license from TI to use such products or services or a warranty or endorsement thereof. Use of such information may require a license from a third party under the patents or other intellectual property of the third party, or a license from TI under the patents or other intellectual property of TI.

Reproduction of information in TI data books or data sheets is permissible only if reproduction is without alteration and is accompanied by all associated warranties, conditions, limitations, and notices. Reproduction of this information with alteration is an unfair and deceptive business practice. TI is not responsible or liable for such altered documentation.

Resale of TI products or services with statements different from or beyond the parameters stated by TI for that product or service voids all express and any implied warranties for the associated TI product or service and is an unfair and deceptive business practice. TI is not responsible or liable for any such statements.

Mailing Address:

Texas Instruments
Post Office Box 655303
Dallas, Texas 75265