

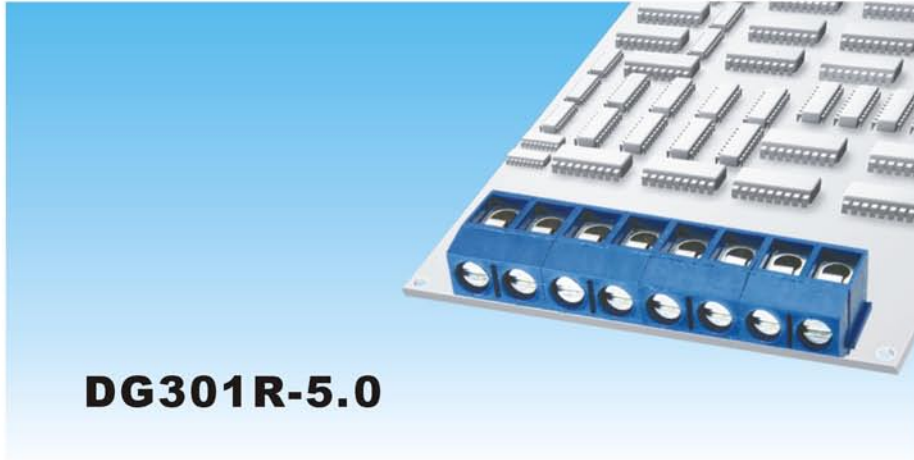

DEGSON ELECTRONICS CO., LTD.

Product Specification



DG301R-5.0

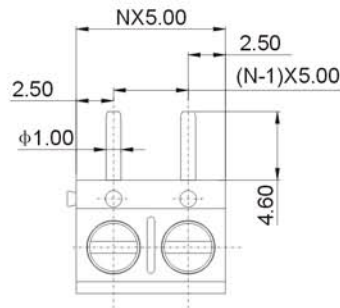

PCB LAYOUT

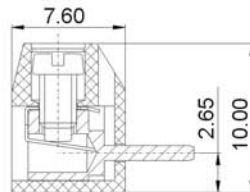
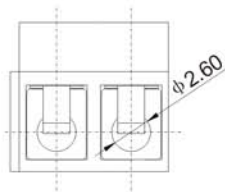
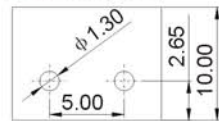

Material

Screws	:	M2.5 steel Zinc plated
Wire guard:		Stainless steel
Pin header:		Brass, Tin plated
Housing	:	PBT, UL94V-0

Electrical

Rated voltage	:	300V
Rated current	:	15A
Contact resistance	:	20mΩ
Insulation resistance	:	5000MΩ /DC 1000V
Withstanding voltage:		AC2000V/1Min
Wire range	:	22-14AWG 1.5mm ²

Mechanical

Temp. Range	:	-30°C~+120°C
Torque	:	0.4Nm(3.6lb.in)
Striplength	:	4.5-5mm

HOW TO ORDER:

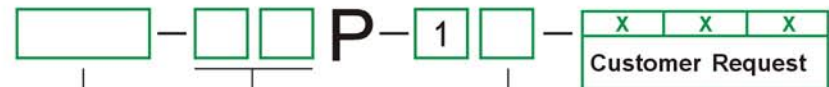

Series No. No of Pole

Color

1	Gray	4	Green	7	Trans-parent
2	Blue	5	Orange	8	Yellow
3	Black	6	Red	9	White



DEGSON ELECTRONICS CO., LTD.

NAME

DG301R-5.0