

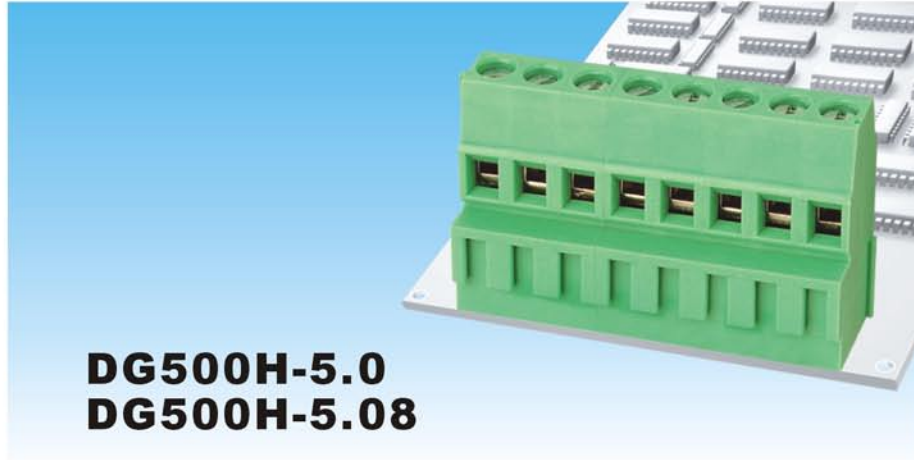

# DEGSON ELECTRONICS CO., LTD.

## Product Specification



**DG500H-5.0**  
**DG500H-5.08**

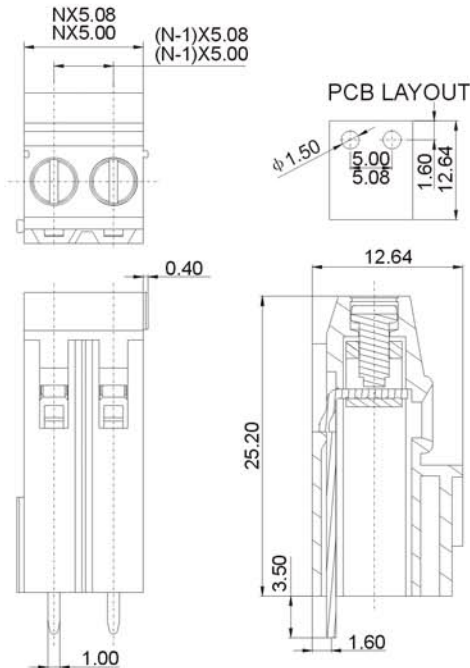

Material	
Screws :	M2.5 steel Zinc plated
Pin header:	Brass, Tin plated
Housing :	PA66, UL94V-0
Electrical	
Rated voltage :	300V
Rated current :	20A
Contact resistance :	20m $\Omega$
Insulation resistance :	5000M $\Omega$ /DC1000V
Withstanding voltage:	AC2000V/1Min
Wire range :	28-12AWG 2.5mm <sup>2</sup>
Mechanical	
Temp. Range :	-40°C~+105°C
Torque :	0.4Nm(3.6lb.in)
Striplength :	6-7mm

### HOW TO ORDER:

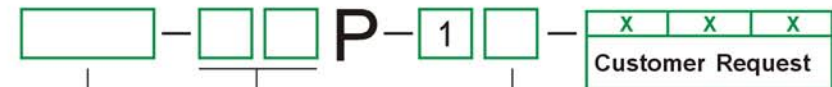

Series No. No of Pole

Color

1 Gray	4 Green	7 Trans- parent
2 Blue	5 Orange	8 Yellow
3 Black	6 Red	9 White

	<b>DEGSON ELECTRONICS CO., LTD.</b>
	NAME <b>DG500H-5.0</b> <b>DG500H-5.08</b>