

PLASTIC-ENCAPSULATE VOLTAGE REGULATORS

FEATURES

- Maximum Output Current I_o : 0.5 A
- Output Voltage V_o : 5 V, 6V, 8V, 9V, 12V, 15V, 18V, 20V, 24V
- Continuous Total Dissipation
 P_D : 1.25 W ($T_a = 25\text{ }^\circ\text{C}$)
- Surface Mount device

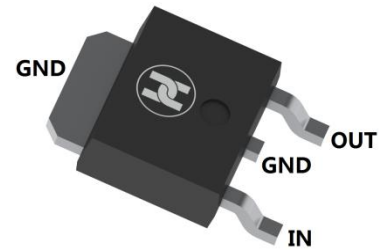

SCHEMATIC DIAGRAM

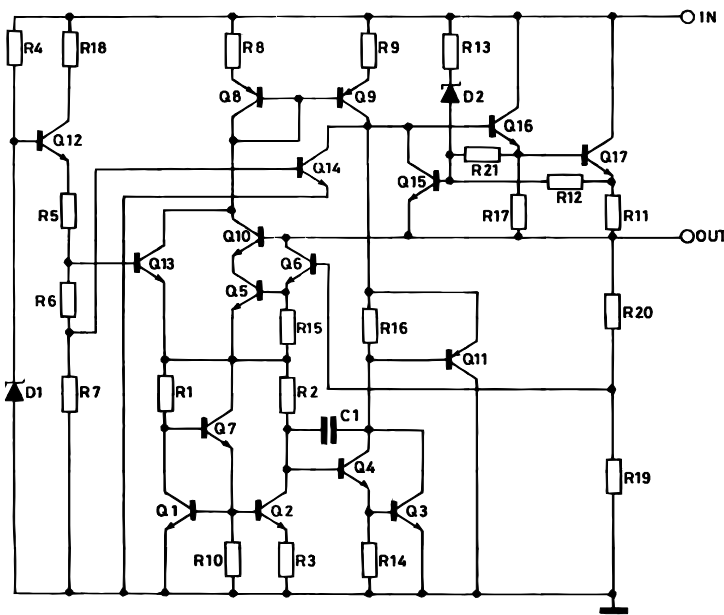

TO-252

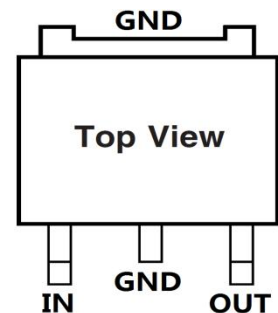

MECHANICAL DATA

- Case: TO-252
- Case Material: Molded Plastic. UL flammability
- Classification Rating: 94V-0
- Weight: 0.055 grams (approximate)

MAXIMUM RATINGS (Operating temperature range applies unless otherwise specified)

Parameter	Symbol	Value	Unit
Input Voltage	V_i	35	V
Power Dissipation	P_D	1250	mW
Thermal Resistance from Junction to Ambient	$R_{\theta JA}$	80	$^\circ\text{C}/\text{W}$
Operating Temperature	T_{opr}	-25~+125	$^\circ\text{C}$
Storage Temperature Range	T_{STG}	-65 ~+150	$^\circ\text{C}$

PLASTIC-ENCAPSULATE VOLTAGE REGULATORS
**ELECTRICAL CHARACTERISTICS OF 78M05 AT SPECIFIED VIRTUAL JUNCTION TEMPERATURE
($V_i=10V, I_o=350mA, C_i=0.33\mu F, C_o=0.1\mu F$, unless otherwise specified)**

Parameter	Symbol	Min	Typ	Max	Unit	Conditions
Output voltage	V_o	4.80	5.0	5.20	V	$T_J=+25^\circ C$
		4.75	5.0	5.25	V	$7V \leq V_i \leq 20V, I_o=5mA \sim 350mA, -25^\circ C \leq T_J \leq +125^\circ C$
Load Regulation	ΔV_o		15	100	mV	$I_o=5mA \sim 500mA, T_J=+25^\circ C$
			5	50	mV	$I_o=5mA \sim 200mA, T_J=+25^\circ C$
Line regulation	ΔV_o		3	100	mV	$7V \leq V_i \leq 25V, I_o=200mA, T_J=+25^\circ C$
			1	50	mV	$8V \leq V_i \leq 25V, I_o=200mA, T_J=+25^\circ C$
Quiescent Current	I_q		4.2	6	mA	$T_J=+25^\circ C$
Quiescent Current Change	ΔI_q			0.8	mA	$8V \leq V_i \leq 25V, -25^\circ C \leq T_J \leq +125^\circ C$
				0.5	mA	$5mA \leq I_o \leq 350mA, -25^\circ C \leq T_J \leq +125^\circ C$
Output Noise Voltage	V_N		42		$\mu V/V_o$	$10Hz \leq f \leq 100kHz, T_J=+25^\circ C$
Ripple Rejection	RR	62	80		dB	$8V \leq V_i \leq 18V, f=120Hz, I_o=300mA, -25^\circ C \leq T_J \leq +125^\circ C$
Dropout Voltage	V_d		2	2.5	V	$I_o=350mA, T_J=+25^\circ C$
Short Circuit Current	I_{SC}		300		mA	$V_i=10V, T_J=+25^\circ C$
Peak Current	I_{pk}		0.5		A	$T_J=+25^\circ C$

*Pulse Test

**ELECTRICAL CHARACTERISTICS OF 78M06 AT SPECIFIED VIRTUAL JUNCTION TEMPERATURE
($V_i=11V, I_o=350mA, C_i=0.33\mu F, C_o=0.1\mu F$, unless otherwise specified)**

Parameter	Symbol	Min	Typ	Max	Unit	Conditions
Output voltage	V_o	5.75	6.0	6.25	V	$T_J=+25^\circ C$
		5.7	6.0	6.3	V	$8V \leq V_i \leq 21V, I_o=5mA \sim 350mA, -25^\circ C \leq T_J \leq +125^\circ C$
Load Regulation	ΔV_o		18	120	mV	$I_o=5mA \sim 500mA, T_J=+25^\circ C$
			10	60	mV	$I_o=5mA \sim 200mA, T_J=+25^\circ C$
Line regulation	ΔV_o		5	100	mV	$8V \leq V_i \leq 25V, I_o=200mA, T_J=+25^\circ C$
			1.5	50	mV	$9V \leq V_i \leq 25V, I_o=200mA, T_J=+25^\circ C$
Quiescent Current	I_q		4.3	6	mA	$T_J=+25^\circ C$
Quiescent Current Change	ΔI_q			0.8	mA	$9V \leq V_i \leq 25V, I_o=200mA, -25^\circ C \leq T_J \leq +125^\circ C$
				0.5	mA	$5mA \leq I_o \leq 350mA, -25^\circ C \leq T_J \leq +125^\circ C$
Output Noise Voltage	V_N		45		$\mu V/V_o$	$10Hz \leq f \leq 100kHz, T_J=+25^\circ C$
Ripple Rejection	RR	59	80		dB	$9V \leq V_i \leq 19V, f=120Hz, I_o=300mA, -25^\circ C \leq T_J \leq +125^\circ C$
Dropout Voltage	V_d		2		V	$I_o=350mA, T_J=+25^\circ C$
Short Circuit Current	I_{SC}		270		mA	$V_i=11V, T_J=+25^\circ C$
Peak Current	I_{pk}		0.5		A	$T_J=+25^\circ C$

*Pulse Test

PLASTIC-ENCAPSULATE VOLTAGE REGULATORS
**ELECTRICAL CHARACTERISTICS OF 78M08 AT SPECIFIED VIRTUAL JUNCTION TEMPERATURE
($V_i=14V, I_o=350mA, C_i=0.33\mu F, C_o=0.1\mu F$, unless otherwise specified)**

Parameter	Symbol	Min	Typ	Max	Unit	Conditions
Output voltage	V_o	7.7	8.0	8.3	V	$T_J=+25^\circ C$
		7.6	8.0	8.4	V	$10.5V \leq V_i \leq 23V, I_o=5mA \sim 350mA, -25^\circ C \leq T_J \leq +125^\circ C$
Load Regulation	ΔV_o		20	160	mV	$I_o=5mA \sim 500mA, T_J=+25^\circ C$
			10	80	mV	$I_o=5mA \sim 200mA, T_J=+25^\circ C$
Line regulation	ΔV_o		6	100	mV	$10.5V \leq V_i \leq 25V, I_o=200mA, T_J=+25^\circ C$
			2	50	mV	$11V \leq V_i \leq 25V, I_o=200mA, T_J=+25^\circ C$
Quiescent Current	I_q		4.6	6	mA	$T_J=+25^\circ C$
Quiescent Current Change	ΔI_q			0.8	mA	$10.5V \leq V_i \leq 25V, I_o=200mA, -25^\circ C \leq T_J \leq +125^\circ C$
				0.5	mA	$5mA \leq I_o \leq 350mA, -25^\circ C \leq T_J \leq +125^\circ C$
Output Noise Voltage	V_N		52		$\mu V/V_o$	$10Hz \leq f \leq 100kHz, T_J=+25^\circ C$
Ripple Rejection	RR	56	80		dB	$11.5V \leq V_i \leq 21.5V, f=120Hz, I_o=300mA, -25^\circ C \leq T_J \leq +125^\circ C$
Dropout Voltage	V_d		2		V	$I_o=350mA, T_J=+25^\circ C$
Short Circuit Current	I_{SC}		250		mA	$V_i=14V, T_J=+25^\circ C$
Peak Current	I_{pk}		0.5		A	$T_J=+25^\circ C$

*Pulse Test

**ELECTRICAL CHARACTERISTICS OF 78M09 AT SPECIFIED VIRTUAL JUNCTION TEMPERATURE
($V_i=16V, I_o=350mA, C_i=0.33\mu F, C_o=0.1\mu F$, unless otherwise specified)**

Parameter	Symbol	Min	Typ	Max	Unit	Conditions
Output voltage	V_o	8.65	9.0	9.35	V	$T_J=+25^\circ C$
		8.55	9.0	9.45	V	$11.5V \leq V_i \leq 24V, I_o=5mA \sim 350mA, -25^\circ C \leq T_J \leq +125^\circ C$
Load Regulation	ΔV_o		20	180	mV	$I_o=5mA \sim 500mA, T_J=+25^\circ C$
			10	90	mV	$I_o=5mA \sim 200mA, T_J=+25^\circ C$
Line regulation	ΔV_o		6	100	mV	$11.5V \leq V_i \leq 26V, I_o=200mA, T_J=+25^\circ C$
			2	50	mV	$12V \leq V_i \leq 26V, I_o=200mA, T_J=+25^\circ C$
Quiescent Current	I_q		4.6	6	mA	$T_J=+25^\circ C$
Quiescent Current Change	ΔI_q			0.8	mA	$11.5V \leq V_i \leq 26V, I_o=200mA, -25^\circ C \leq T_J \leq +125^\circ C$
				0.5	mA	$5mA \leq I_o \leq 350mA, -25^\circ C \leq T_J \leq +125^\circ C$
Output Noise Voltage	V_N		60		$\mu V/V_o$	$10Hz \leq f \leq 100kHz, T_J=+25^\circ C$
Ripple Rejection	RR	56	80		dB	$13V \leq V_i \leq 23V, f=120Hz, I_o=300mA, -25^\circ C \leq T_J \leq +125^\circ C$
Dropout Voltage	V_d		2		V	$I_o=350mA, T_J=+25^\circ C$
Short Circuit Current	I_{SC}		250		mA	$V_i=16V, T_J=+25^\circ C$
Peak Current	I_{pk}		0.5		A	$T_J=+25^\circ C$

*Pulse Test

PLASTIC-ENCAPSULATE VOLTAGE REGULATORS
**ELECTRICAL CHARACTERISTICS OF 78M12 AT SPECIFIED VIRTUAL JUNCTION TEMPERATURE
($V_i=19V, I_o=350mA, C_i=0.33\mu F, C_o=0.1\mu F$, unless otherwise specified)**

Parameter	Symbol	Min	Typ	Max	Unit	Conditions
Output voltage	V_o	11.5	12	12.5	V	$T_J=+25^\circ C$
		11.4	12	12.6	V	$14.5V \leq V_i \leq 27V, I_o=5mA \sim 350mA, -25^\circ C \leq T_J \leq +125^\circ C$
Load Regulation	ΔV_o		25	240	mV	$I_o=5mA \sim 500mA, T_J=+25^\circ C$
			10	120	mV	$I_o=5mA \sim 200mA, T_J=+25^\circ C$
Line regulation	ΔV_o		10	100	mV	$14.5V \leq V_i \leq 30V, I_o=200mA, T_J=+25^\circ C$
			3	50	mV	$16V \leq V_i \leq 30V, I_o=200mA, T_J=+25^\circ C$
Quiescent Current	I_q		4.6	6	mA	$T_J=+25^\circ C$
Quiescent Current Change	ΔI_q			0.8	mA	$14.5V \leq V_i \leq 30V, I_o=200mA, -25^\circ C \leq T_J \leq +125^\circ C$
				0.5	mA	$5mA \leq I_o \leq 350mA, -25^\circ C \leq T_J \leq +125^\circ C$
Output Voltage Drift	$\Delta V/\Delta T$		-0.5		mV/ $^\circ C$	$I_o=5mA, -25^\circ C \leq T_J \leq +125^\circ C$
Output Noise Voltage	V_N		75		$\mu V/V_o$	$10Hz \leq f \leq 100kHz, T_J=+25^\circ C$
Ripple Rejection	RR	55	80		dB	$15V \leq V_i \leq 25V, f=120Hz, I_o=300mA, -25^\circ C \leq T_J \leq +125^\circ C$
Dropout Voltage	V_d		2		V	$I_o=350mA, T_J=+25^\circ C$
Short Circuit Current	I_{SC}		300		mA	$V_i=35V, T_J=+25^\circ C$
Peak Current	I_{pk}		700		mA	$T_J=+25^\circ C$

*Pulse Test

**ELECTRICAL CHARACTERISTICS OF 78M15 AT SPECIFIED VIRTUAL JUNCTION TEMPERATURE
($V_i=23V, I_o=350mA, C_i=0.33\mu F, C_o=0.1\mu F$, unless otherwise specified)**

Parameter	Symbol	Min	Typ	Max	Unit	Conditions
Output voltage	V_o	14.4	15	15.6	V	$V_i=23V, I_o=350mA, T_J=+25^\circ C$
		14.25	15	15.75	V	$17.5V \leq V_i \leq 30V, I_o=5mA \sim 350mA, -25^\circ C \leq T_J \leq +125^\circ C$
Load Regulation	ΔV_o			300	mV	$I_o=5mA \sim 500mA, T_J=+25^\circ C$
				150	mV	$I_o=5mA \sim 200mA, T_J=+25^\circ C$
Line regulation	ΔV_o			100	mV	$17.5V \leq V_i \leq 30V, I_o=200mA, T_J=+25^\circ C$
				50	mV	$20V \leq V_i \leq 26V, I_o=200mA, T_J=+25^\circ C$
Quiescent Current	I_q		4.1	6	mA	$V_i=23V, I_o=350mA, T_J=+25^\circ C$
Quiescent Current Change	ΔI_q			0.8	mA	$17.5V \leq V_i \leq 30V, I_o=200mA, -25^\circ C \leq T_J \leq +125^\circ C$
				0.5	mA	$V_i=23V, 5mA \leq I_o \leq 350mA, -25^\circ C \leq T_J \leq +125^\circ C$
Output Voltage Drift	$\Delta V/\Delta T$		-1		mV/ $^\circ C$	$I_o=5mA, -25^\circ C \leq T_J \leq +125^\circ C$
Output Noise Voltage	V_N		100		$\mu V/V_o$	$10Hz \leq f \leq 100kHz, T_J=+25^\circ C$
Ripple Rejection	RR		70		dB	$18.5V \leq V_i \leq 28.5V, f=120Hz, I_o=300mA, -25^\circ C \leq T_J \leq +125^\circ C$
Dropout Voltage	V_d		2		V	$T_J=+25^\circ C$
Short Circuit Current	I_{SC}		300		mA	$V_i=35V, T_J=+25^\circ C$
Peak Current	I_{pk}		700		mA	$T_J=+25^\circ C$

*Pulse Test

PLASTIC-ENCAPSULATE VOLTAGE REGULATORS
**ELECTRICAL CHARACTERISTICS OF 78M18 AT SPECIFIED VIRTUAL JUNCTION TEMPERATURE
($V_i=26V, I_o=350mA, C_i=0.33\mu F, C_o=0.1\mu F$, unless otherwise specified)**

Parameter	Symbol	Min	Typ	Max	Unit	Conditions
Output voltage	V_o	17.3	18	18.7	V	$V_i=26V, I_o=350mA, T_J=+25^\circ C$
		17.1	18	18.9	V	$20.5V \leq V_i \leq 33V, I_o=5mA \sim 350mA, -25^\circ C \leq T_J \leq +125^\circ C$
Load Regulation	ΔV_o			360	mV	$I_o=5mA \sim 500mA, T_J=+25^\circ C$
				180	mV	$I_o=5mA \sim 200mA, T_J=+25^\circ C$
Line regulation	ΔV_o			100	mV	$21V \leq V_i \leq 33V, I_o=200mA, T_J=+25^\circ C$
				50	mV	$24V \leq V_i \leq 33V, I_o=200mA, T_J=+25^\circ C$
Quiescent Current	I_q		4.2	6	mA	$V_i=26V, I_o=350mA, T_J=+25^\circ C$
Quiescent Current Change	ΔI_q			0.8	mA	$21V \leq V_i \leq 33V, I_o=200mA, -25^\circ C \leq T_J \leq +125^\circ C$
				0.5	mA	$V_i=26V, 5mA \leq I_o \leq 350mA, -25^\circ C \leq T_J \leq +125^\circ C$
Output Voltage Drift	$\Delta V/\Delta T$		-1.1		mV/ $^\circ C$	$I_o=5mA, -25^\circ C \leq T_J \leq +125^\circ C$
Output Noise Voltage	V_N		100		$\mu V/V_o$	$10Hz \leq f \leq 100kHz, T_J=+25^\circ C$
Ripple Rejection	RR		70		dB	$22V \leq V_i \leq 32V, f=120Hz, I_o=300mA, -25^\circ C \leq T_J \leq +125^\circ C$
Dropout Voltage	V_d		2		V	$T_J=+25^\circ C, I_o=500mA$
Short Circuit Current	I_{SC}		300		mA	$T_J=+25^\circ C, V_i=35V$
Peak Current	I_{PK}		700		mA	$T_J=+25^\circ C$

*Pulse Test

**ELECTRICAL CHARACTERISTICS OF 78M20 AT SPECIFIED VIRTUAL JUNCTION TEMPERATURE
($V_i=29V, I_o=350mA, C_i=0.33\mu F, C_o=0.1\mu F$, unless otherwise specified)**

Parameter	Symbol	Min	Typ	Max	Unit	Conditions
Output voltage	V_o	19.2	20	20.8	V	$V_i=29V, I_o=350mA, T_J=+25^\circ C$
		19	20	21	V	$23V \leq V_i \leq 35V, I_o=5mA \sim 350mA, -25^\circ C \leq T_J \leq +125^\circ C$
Load Regulation	ΔV_o			400	mV	$I_o=5mA \sim 500mA, T_J=+25^\circ C$
				200	mV	$I_o=5mA \sim 200mA, T_J=+25^\circ C$
Line regulation	ΔV_o			100	mV	$23V \leq V_i \leq 35V, I_o=200mA, T_J=+25^\circ C$
				50	mV	$24V \leq V_i \leq 35V, I_o=200mA, T_J=+25^\circ C$
Quiescent Current	I_q		4.2	6	mA	$V_i=29V, I_o=350mA, T_J=+25^\circ C$
Quiescent Current Change	ΔI_q			0.8	mA	$23V \leq V_i \leq 35V, I_o=200mA, -25^\circ C \leq T_J \leq +125^\circ C$
				0.5	mA	$V_i=29V, 5mA \leq I_o \leq 350mA, -25^\circ C \leq T_J \leq +125^\circ C$
Output Voltage Drift	$\Delta V/\Delta T$		-1.2		mV/ $^\circ C$	$I_o=5mA, -25^\circ C \leq T_J \leq +125^\circ C$
Output Noise Voltage	V_N		140		$\mu V/V_o$	$10Hz \leq f \leq 100kHz, T_J=+25^\circ C$
Ripple Rejection	RR		70		dB	$24V \leq V_i \leq 34V, f=120Hz, I_o=300mA, -25^\circ C \leq T_J \leq +125^\circ C$
Dropout Voltage	V_d		2		V	$T_J=+25^\circ C, I_o=500mA$
Short Circuit Current	I_{SC}		300		mA	$T_J=+25^\circ C, V_i=35V$
Peak Current	I_{PK}		700		mA	$T_J=+25^\circ C$

*Pulse Test

PLASTIC-ENCAPSULATE VOLTAGE REGULATORS
**ELECTRICAL CHARACTERISTICS OF 78M24 AT SPECIFIED VIRTUAL JUNCTION TEMPERATURE
($V_i=33V, I_o=350mA, C_i=0.33\mu F, C_o=0.1\mu F$, unless otherwise specified)**

Parameter	Symbol	Min	Typ	Max	Unit	Conditions
Output voltage	V_o	23	24	25	V	$V_i=33V, I_o=350mA, T_J=+25^\circ C$
		22.8	24	25.2	V	$27V \leq V_i \leq 38V, I_o=5mA \sim 350mA, -25^\circ C \leq T_J \leq +125^\circ C$
Load Regulation	ΔV_o			480	mV	$I_o=5mA \sim 500mA, T_J=+25^\circ C$
				240	mV	$I_o=5mA \sim 200mA, T_J=+25^\circ C$
Line regulation	ΔV_o			100	mV	$27V \leq V_i \leq 38V, I_o=200mA, T_J=+25^\circ C$
				50	mV	$28V \leq V_i \leq 38V, I_o=200mA, T_J=+25^\circ C$
Quiescent Current	I_q		4.2	6	mA	$V_i=33V, I_o=350mA, T_J=+25^\circ C$
Quiescent Current Change	ΔI_q			0.8	mA	$27V \leq V_i \leq 38V, I_o=200mA, -25^\circ C \leq T_J \leq +125^\circ C$
				0.5	mA	$V_i=33V, 5mA \leq I_o \leq 350mA, -25^\circ C \leq T_J \leq +125^\circ C$
Output Voltage Drift	$\Delta V/\Delta T$		-1.2		mV/ $^\circ C$	$I_o=5mA, -25^\circ C \leq T_J \leq +125^\circ C$
Output Noise Voltage	V_N		170		$\mu V/V_o$	$10Hz \leq f \leq 100kHz, T_J=+25^\circ C$
Ripple Rejection	RR		70		dB	$28V \leq V_i \leq 38V, f=120Hz, I_o=300mA, -25^\circ C \leq T_J \leq +125^\circ C$
Dropout Voltage	V_d		2		V	$T_J=+25^\circ C, I_o=500mA$
Short Circuit Current	I_{SC}		300		mA	$T_J=+25^\circ C, V_i=35V$
Peak Current	I_{PK}		700		mA	$T_J=+25^\circ C$

*Pulse Test

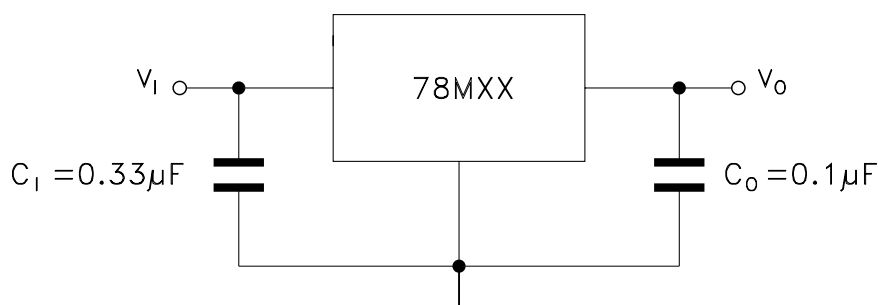
TYPICAL APPLICATION

Note: Bypass capacitors are recommended for optimum stability and transient response and should be located as close as Possible to the regulators.

PLASTIC-ENCAPSULATE VOLTAGE REGULATORS

Test Circuits

DC Parameter

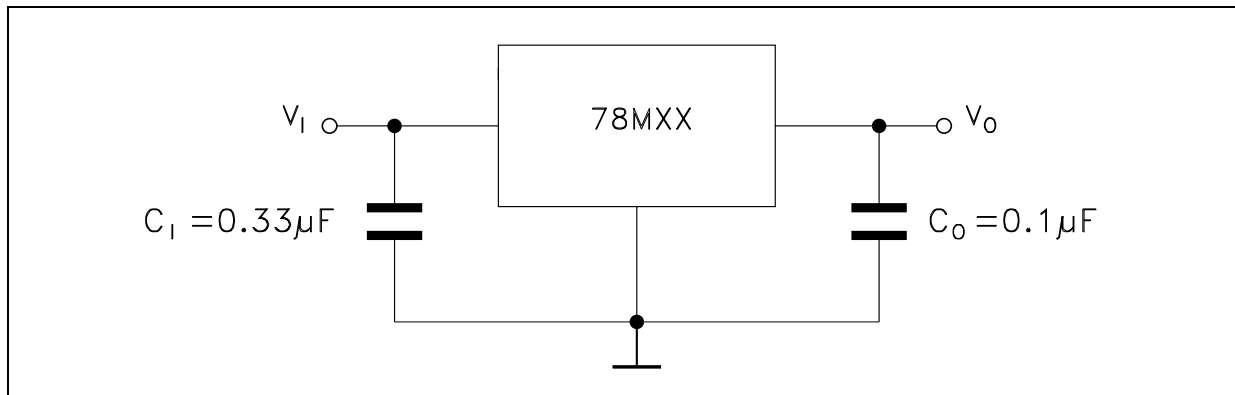

Load regulation

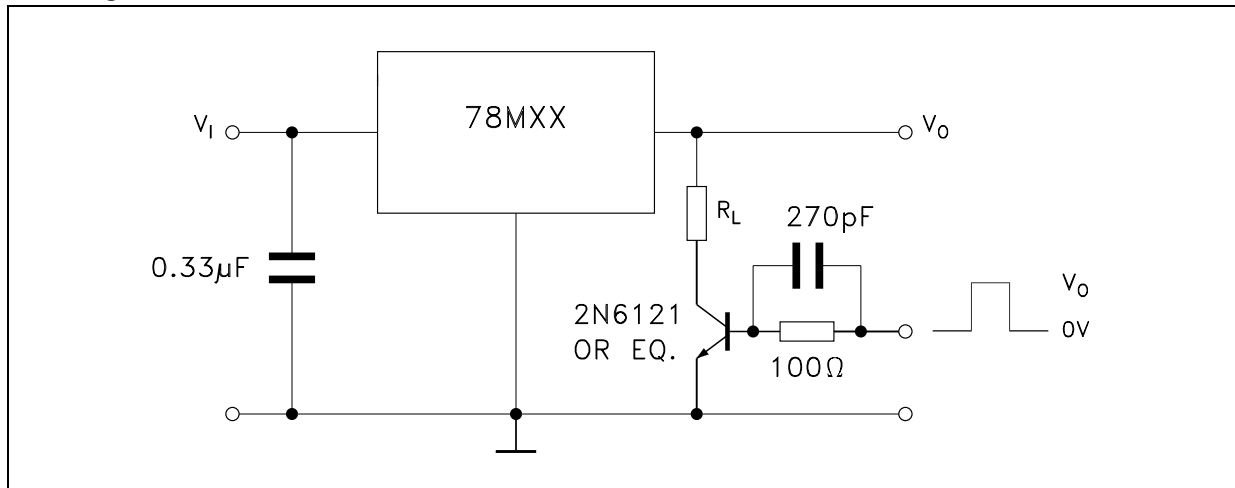

Ripple rejection

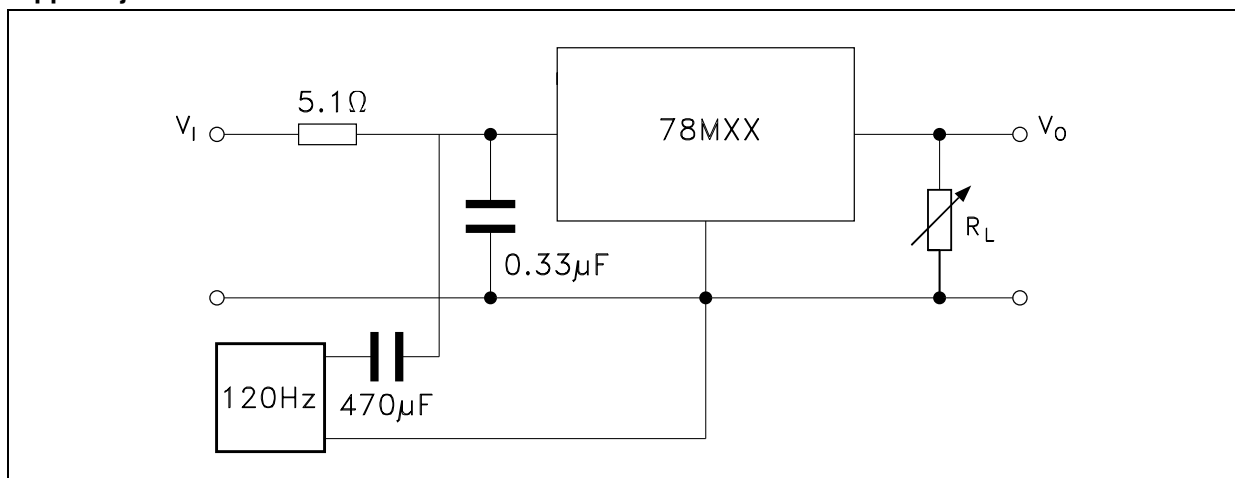

PLASTIC-ENCAPSULATE VOLTAGE REGULATORS

Typical Characteristics

Dropout voltage vs junction temp.

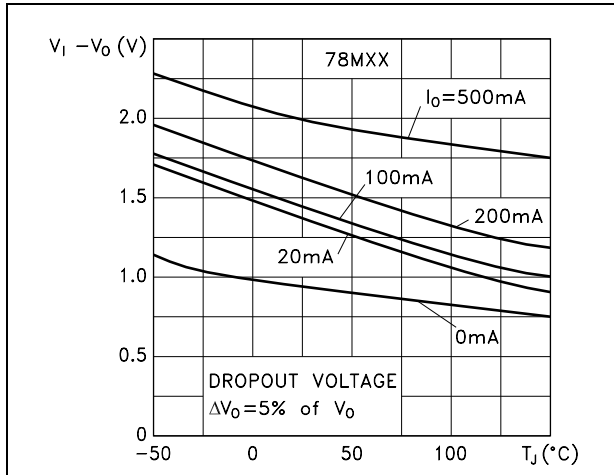

Dropout characteristics

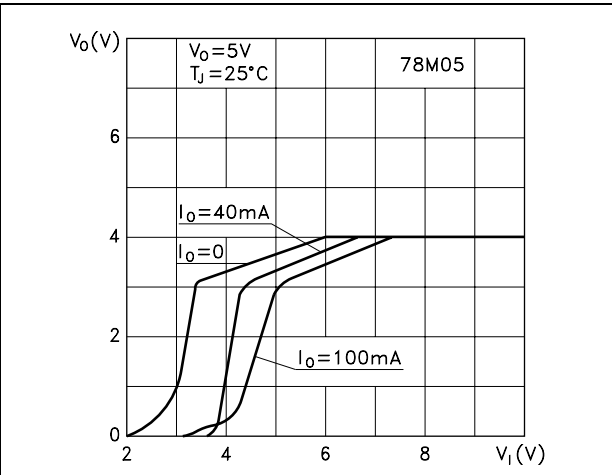

Peak output current vs input-output differential voltage

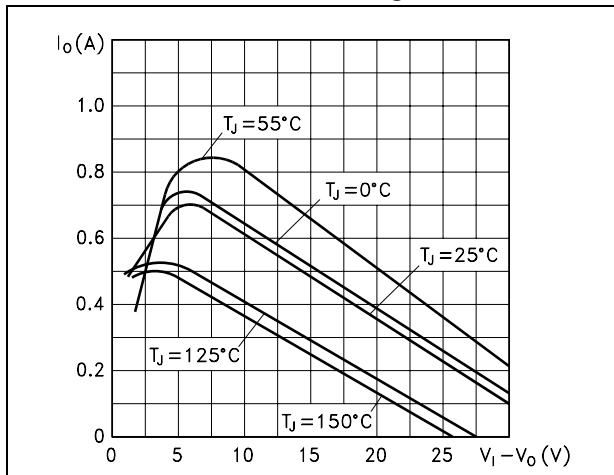

Output voltage vs junction temperature

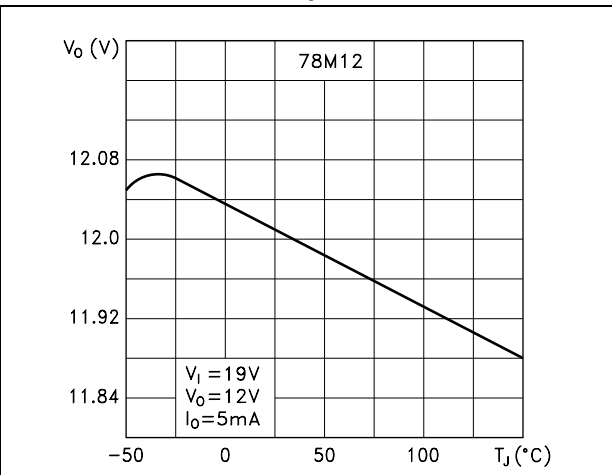

Supply voltage rejection vs freq.

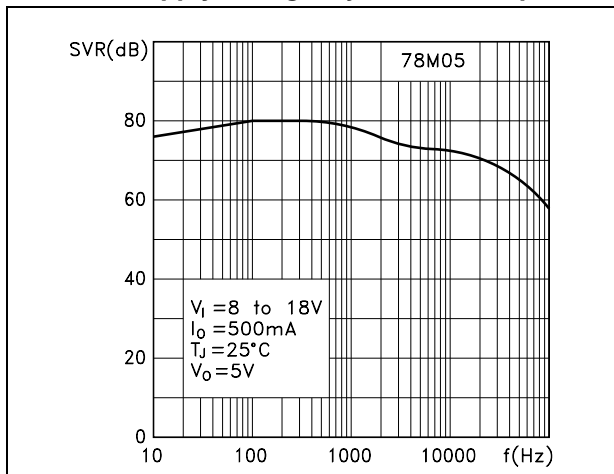

Quiescent current vs junction temp.

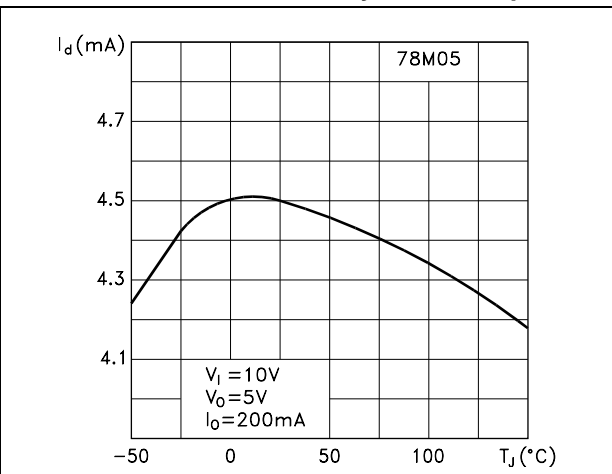

PLASTIC-ENCAPSULATE VOLTAGE REGULATORS

Load transient response

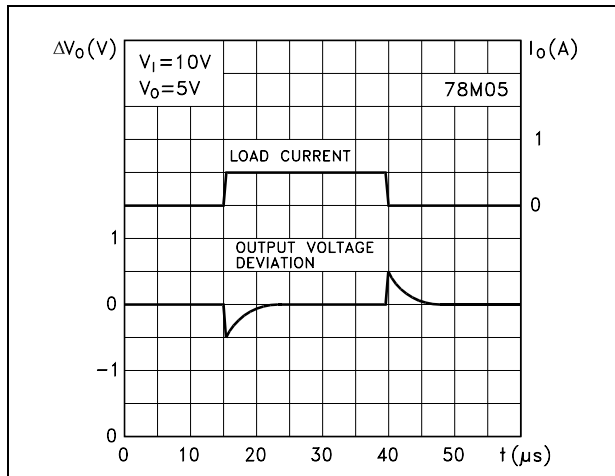

Line transient response

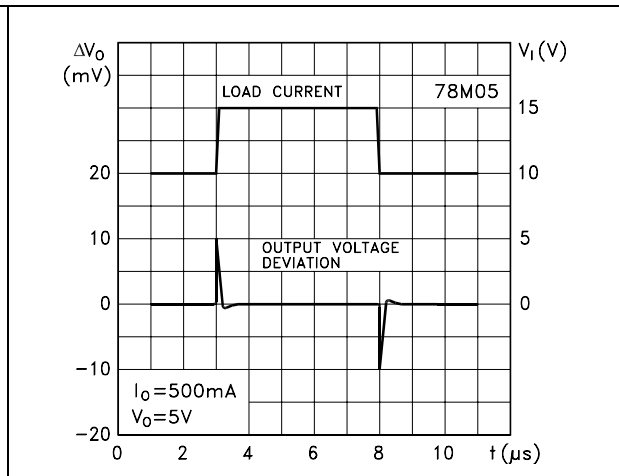

Quiescent current vs input voltage

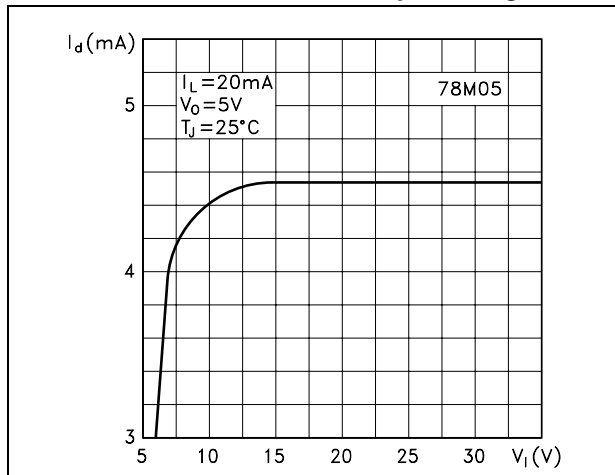

PLASTIC-ENCAPSULATE VOLTAGE REGULATORS

Fixed output regulator

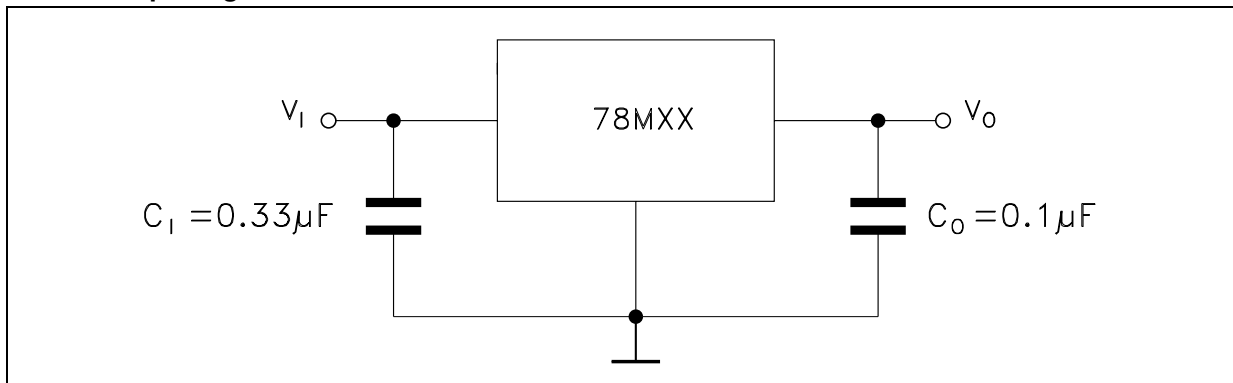

1. To specify an output voltage, substitute voltage value for "XX".
2. Although no output capacitor is need for stability, it does improve transient response.
3. Required if regulator is locate an appreciable distance from power supply filter.

Constant current regulator

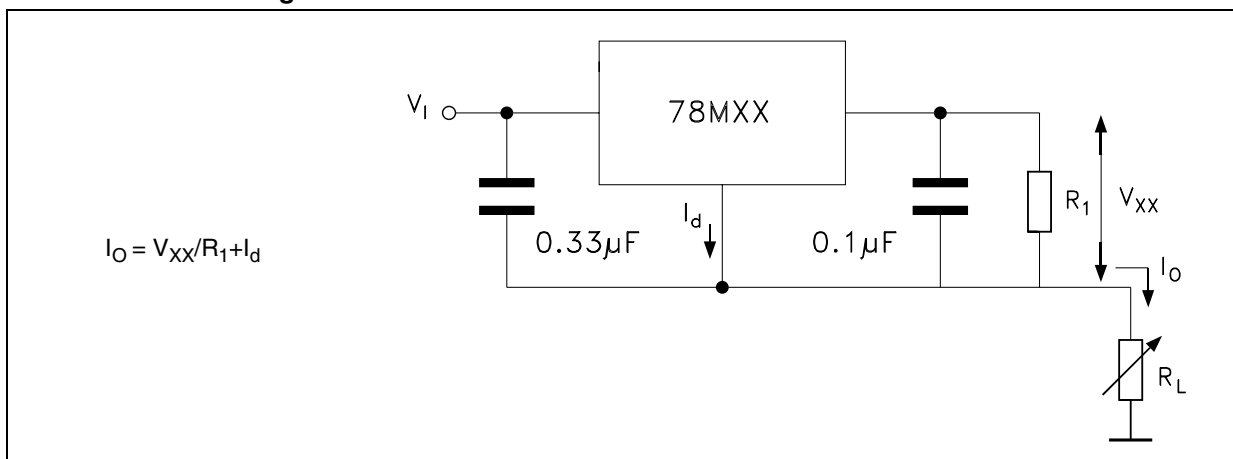

$I_o = V_{XX}/R_1 + I_d$

Circuit for increasing output voltage

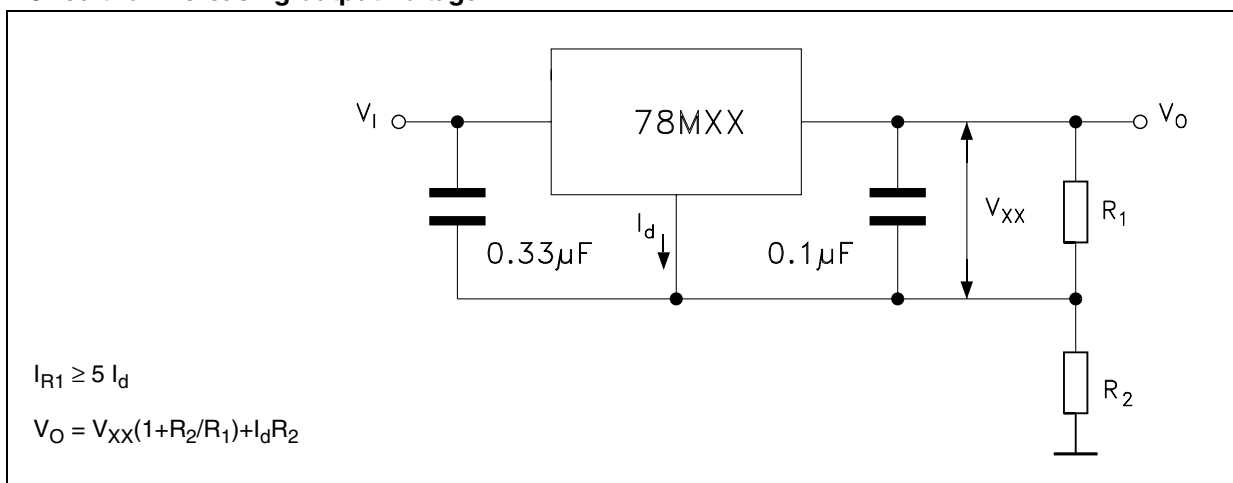

$I_{R1} \geq 5 I_d$

$V_o = V_{XX}(1 + R_2/R_1) + I_d R_2$

PLASTIC-ENCAPSULATE VOLTAGE REGULATORS

Adjustable output regulator (7 to 30V)

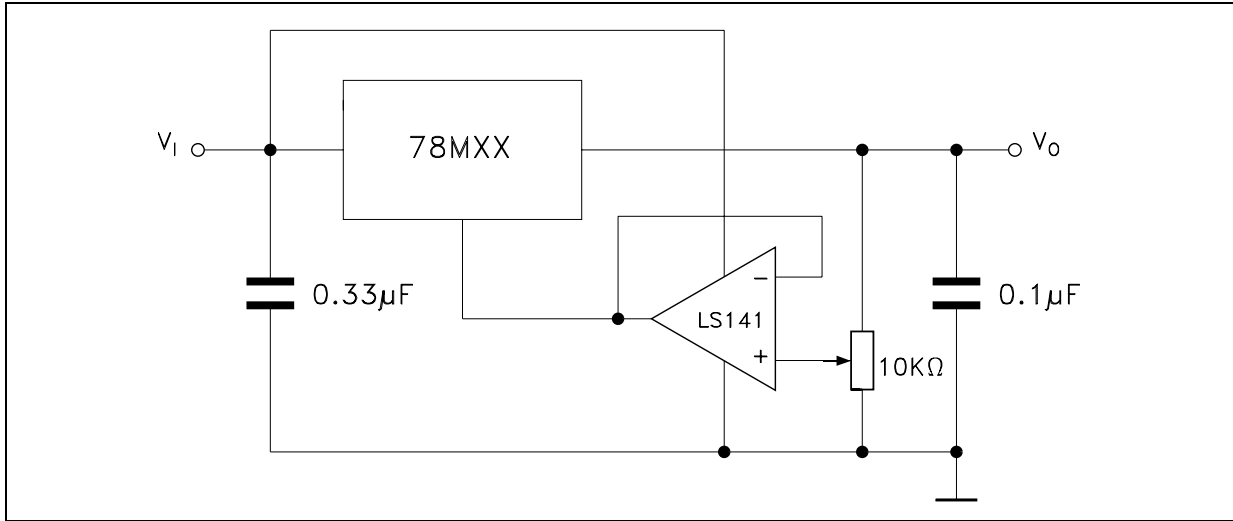

0.5 to 10V Regulator

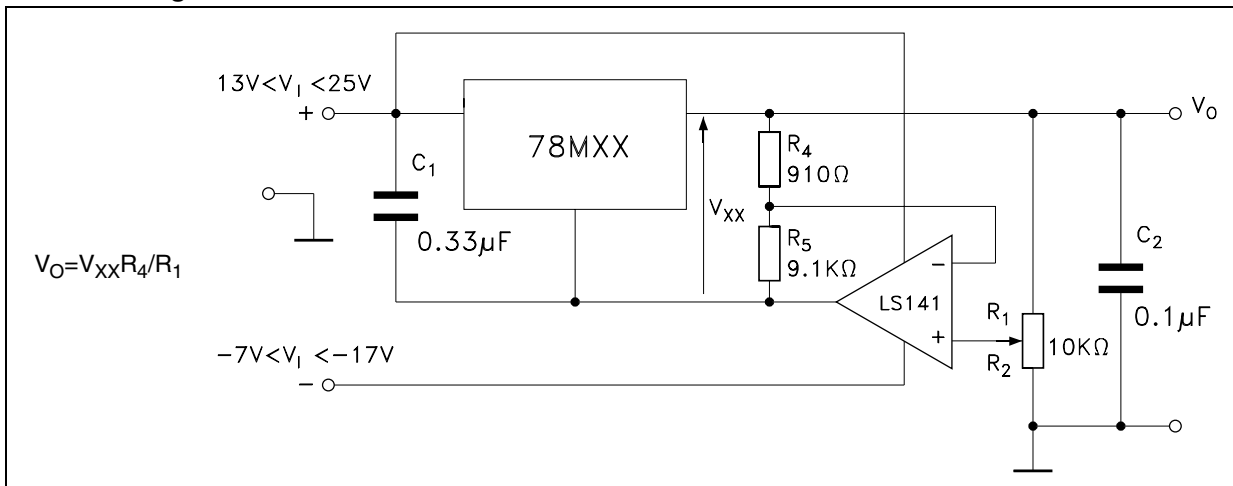

High current voltage regulator

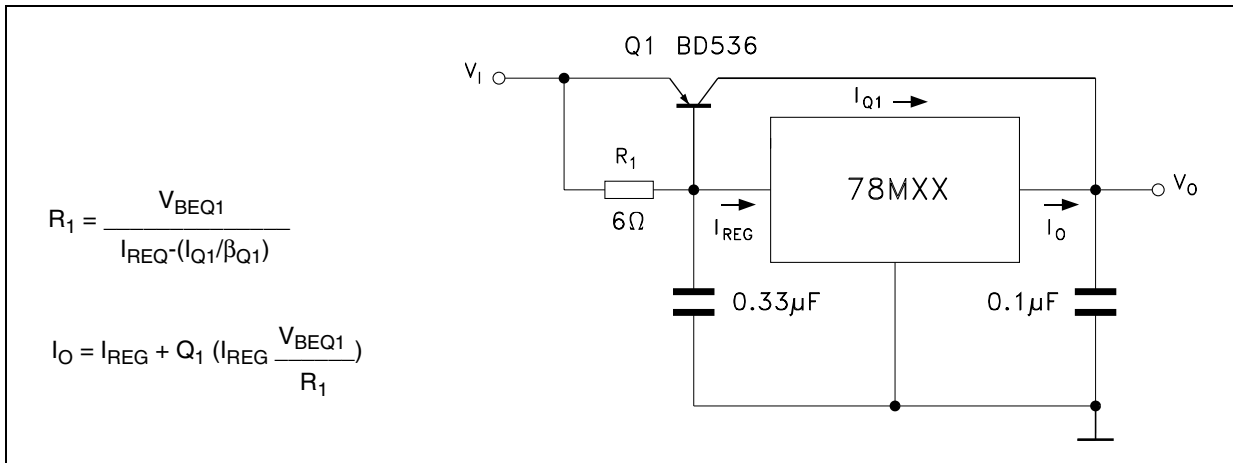

PLASTIC-ENCAPSULATE VOLTAGE REGULATORS

High output current with short circuit protection

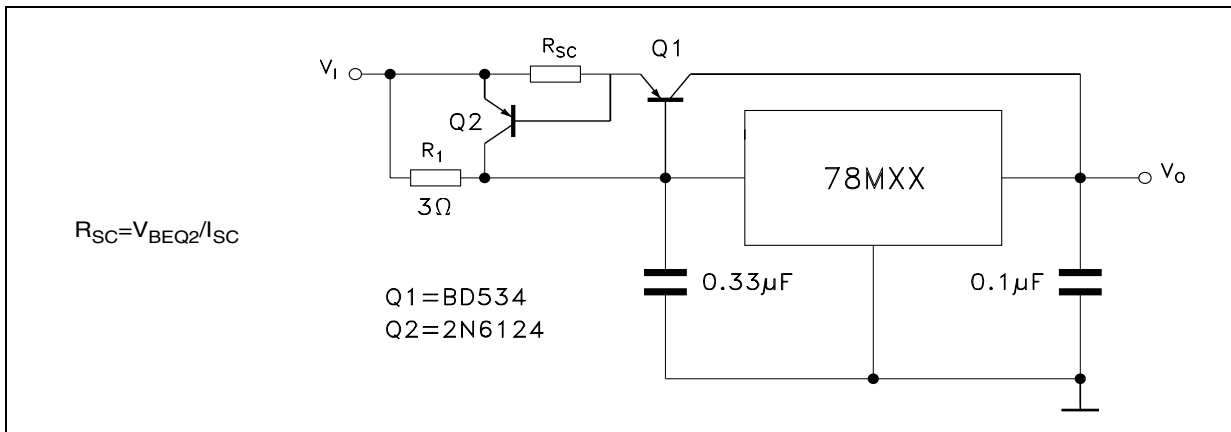

Tracking voltage regulator

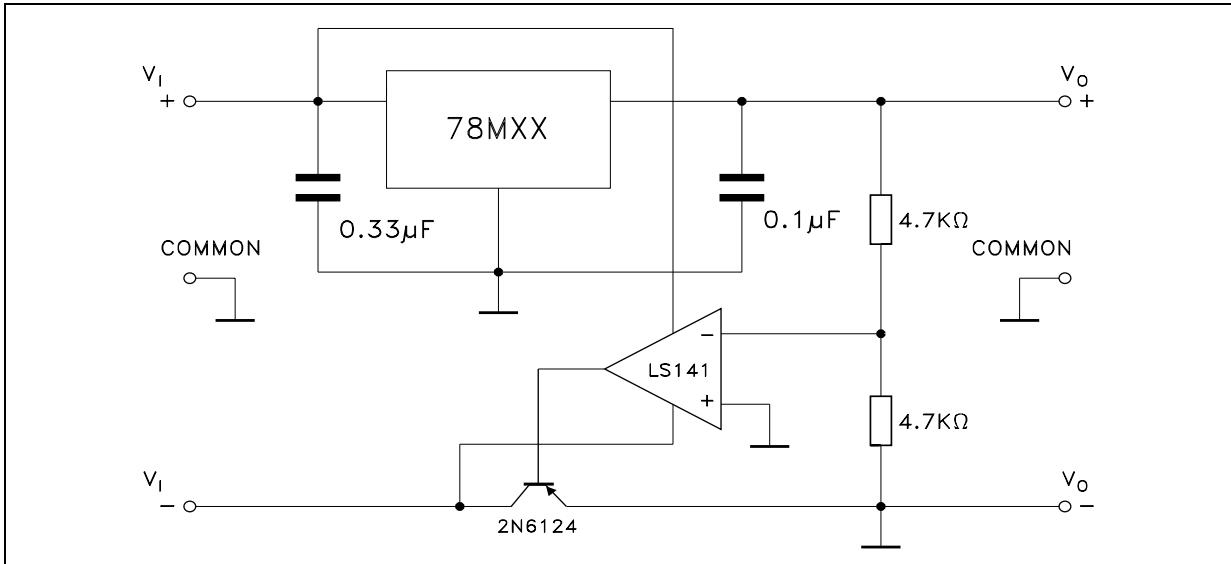

Adjustable output voltage with temperature compensation

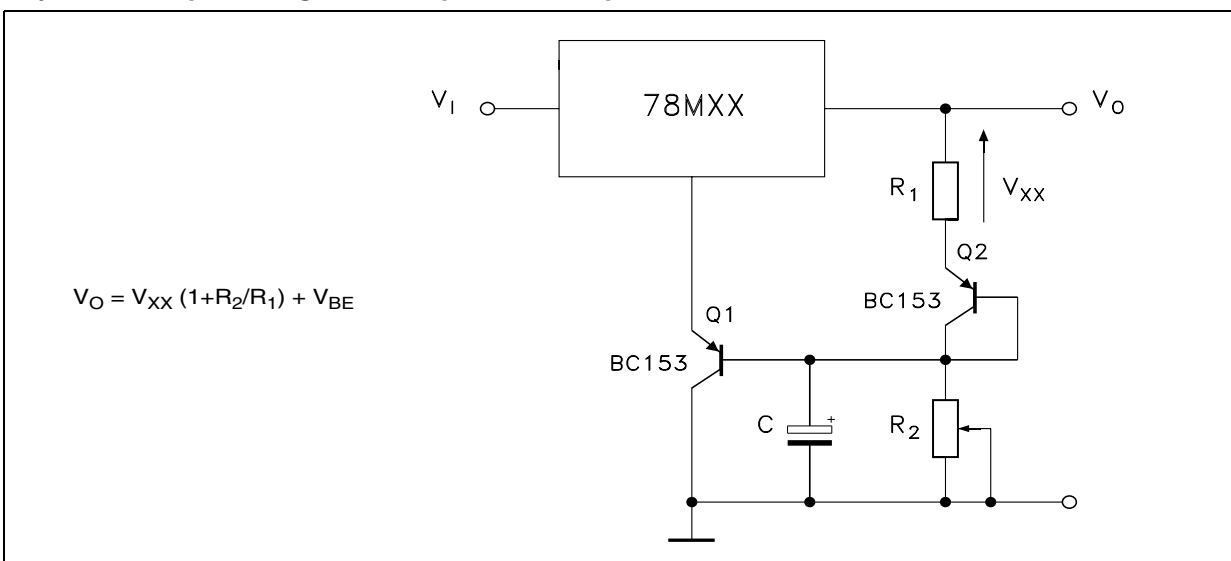

Note: Q₂ is connected as a diode in order to compensate the variation of the Q₁ V_{BE} with the temperature. C allows a slow rise time of the V_O.

PLASTIC-ENCAPSULATE VOLTAGE REGULATORS

High input voltage circuit

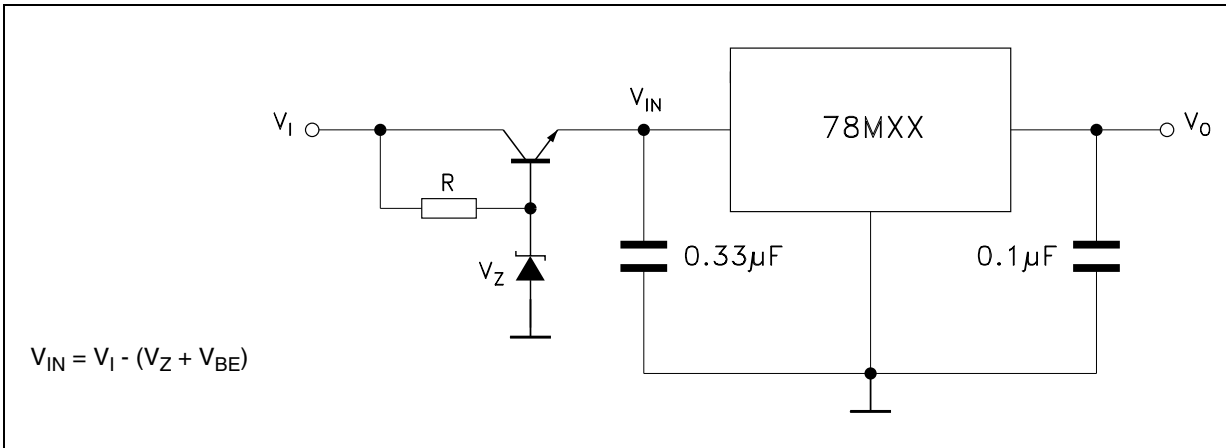

Reducing power dissipation with dropping resistor

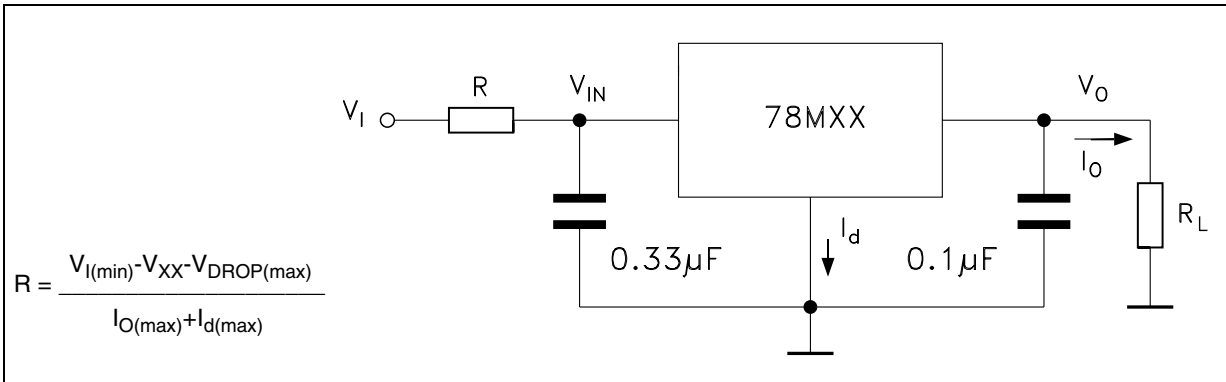

Power AM Modulator (unity voltage gain, $I_O \leq 0.5A$)

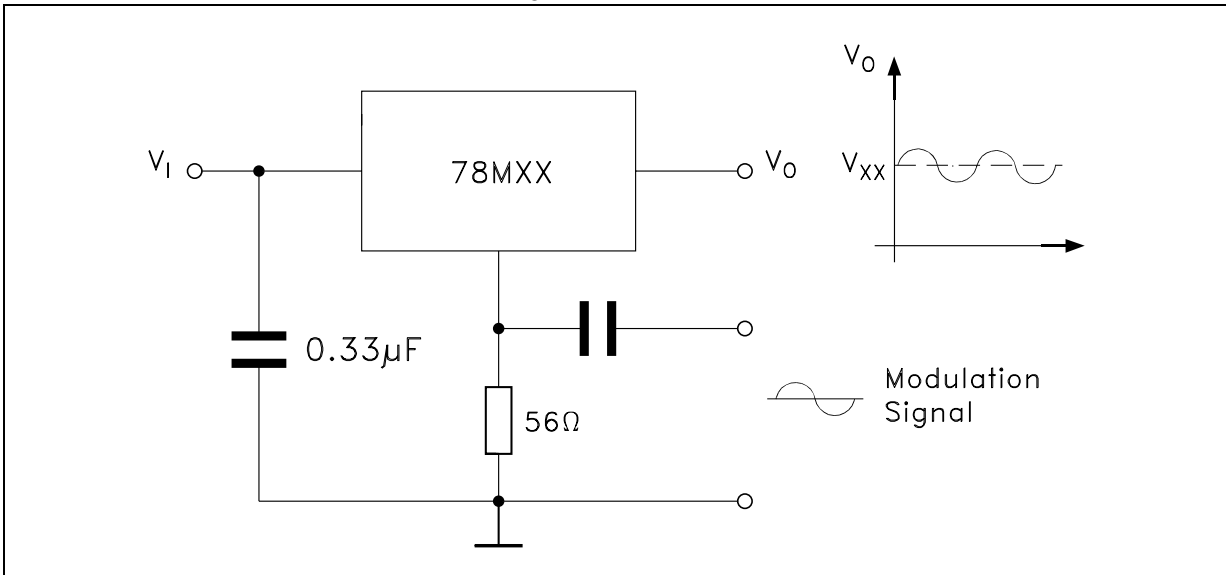

Note: The circuit performs well up to 100 KHz.

PLASTIC-ENCAPSULATE VOLTAGE REGULATORS

TO-252 Package Outline Dimensions

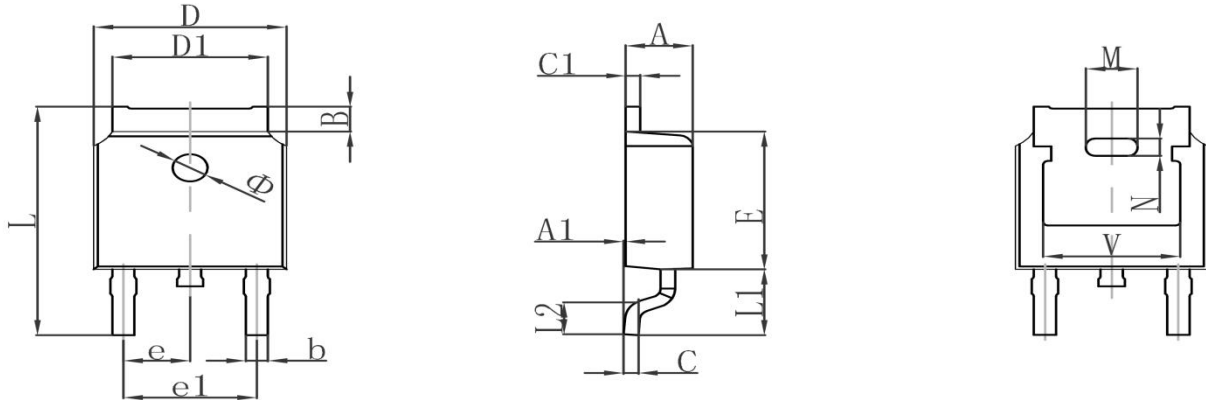

Symbol	Dimensions In Millimeters		Dimensions In Inches	
	Min.	Max.	Min.	Max.
A	2.200	2.380	0.087	0.094
A1	0.000	0.100	0.000	0.004
B	0.800	1.400	0.031	0.055
b	0.710	0.810	0.028	0.032
c	0.460	0.560	0.018	0.022
c1	0.460	0.560	0.018	0.022
D	6.500	6.700	0.256	0.264
D1	5.130	5.460	0.202	0.215
E	6.000	6.200	0.236	0.244
e	2.286TYP		0.090TYP	
e1	4.327	4.727	0.170	0.186
M	1.778REF		0.070REF	
N	0.762REF		0.018REF	
L	9.800	10.400	0.386	0.409
L1	2.9REF		0.114REF	
L2	1.400	1.700	0.055	0.067
V	4.830REF		0.190REF	
Φ	1.100	1.300	0.043	0.051

TO-252 Suggested Pad Layout

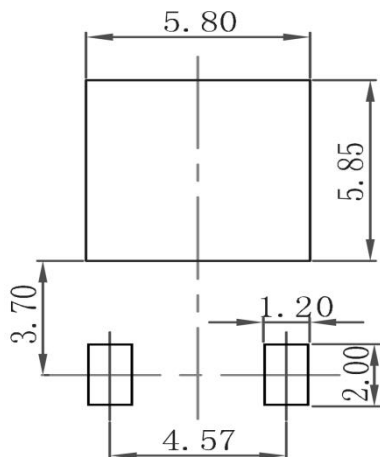

Note:

1. Controlling dimension: in millimeters
2. General tolerance: ±0.05mm
3. The pad layout is for reference purposes only

PLASTIC-ENCAPSULATE VOLTAGE REGULATORS

TO-252 Tape and Reel

TO-252 Embossed Carrier Tape

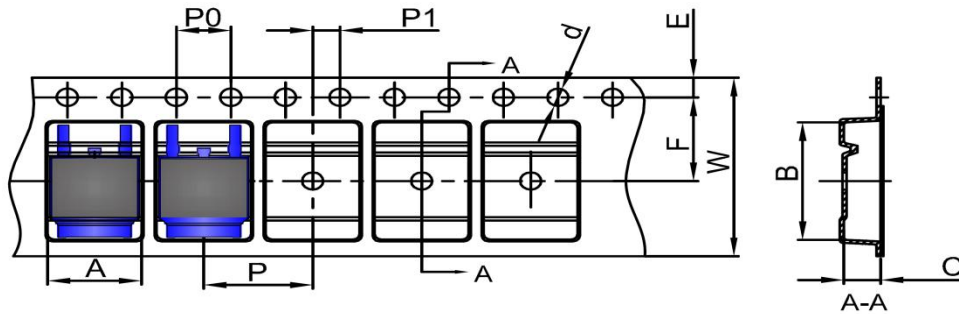

DIMENSIONS ARE IN MILLIMETER										
TYPE	A	B	C	d	E	F	P0	P	P1	W
TO-252	6.90	10.50	2.70	Ø1.55	1.75	7.50	4.00	8.00	2.00	16.00
TOLERANCE	±0.1	±0.1	±0.1	±0.1	±0.1	±0.1	±0.1	±0.1	±0.1	±0.1

TO-252 Tape Leader and Trailer

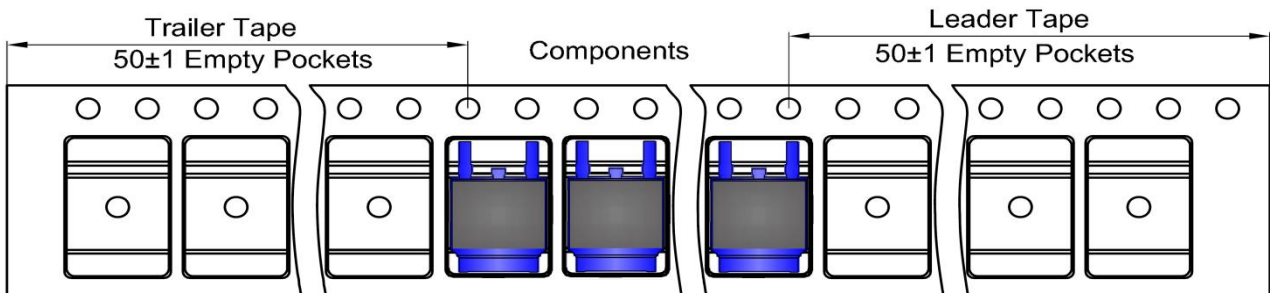

TO-252 Reel

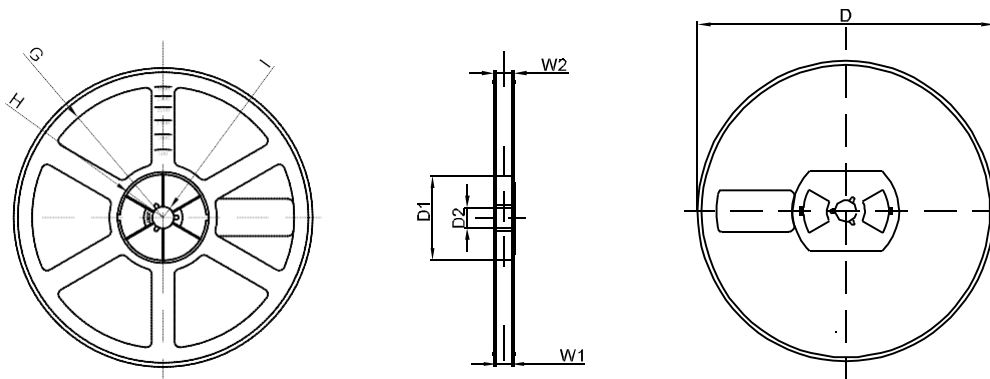

DIMENSIONS ARE IN MILLIMETER								
REEL OPTION	D	D1	D2	G	H	I	W1	W2
13" DIA	Ø330.00	100.00	Φ21.00	R151.00	R56.00	R6.50	16.40	21.00
TOLERANCE	±2	±1	±1	±1	±1	±1	±1	±1