



HOA1887-013

HOA Series Transmissive Sensor, Darlington Output, Plastic Package

Features

- Choice of phototransistor or photodarlington output
- Side mount package
- Ambient light and dust protective filter
- Accurate position sensing
- 0.010 in [0.25 mm] aperture windows
- 0.125 in [3.18 mm] slot width
- 24.0 in [610 mm] min. 26 AWG UL 1429 wire leads

Description

The HOA1887 series consists of an infrared emitting diode facing an NPN silicon phototransistor (HOA1887-011, -012) or photodarlington (HOA1887-013) encased in a black thermoplastic housing. Detector switching takes place whenever an opaque object passes through the slot between emitter and detector. The side mounting package is useful in applications in which the interruptive element is parallel to the mounting plane. Both emitter and detector have a 0.010 in (0.25 mm) x 0.60 in (1.52 mm) vertical aperture. This feature is ideal for use in applications in which maximum position resolution is desired.

All devices employ a built-in strain relief for maximum wire attachment strength. The sensor housing contains IR transmissive optical windows. This arrangement provides excellent protection against ambient light while eliminating aperture openings which could be clogged by airborne contaminants. The HOA1887 series contains plastic molded components. For additional component information see SEP8506, SDP8406, and SDP8106.

Housing material is polycarbonate. Housings are soluble in chlorinated hydrocarbons and ketones. Recommended cleaning agents are methanol and isopropanol.

Representative photograph, actual product appearance may vary.

Due to regional agency approval requirements, some products may not be available in your area. Please contact your regional Honeywell office regarding your product of choice.

Wire color and functions are:

Red - IRED Anode

Black - IRED Cathode

White - Detector Collector

Green - Detector Emitter



HOA1887-013

HOA Series Transmissive Sensor, Darlington Output, Plastic Package

Product Specifications	
Product Type	IR Switch
On-State Collector Current	4.00 mA
Output	Darlington
Package Components	Plastic
Package Color	Black
Forward Current	20 mA
Continuous Forward Current	50 mA
Forward Voltage	1.6 V
Reverse Breakdown Voltage	3 V
Reverse Current	10 μ A
Housing Material	Polycarbonate
Rise and Fall Time	75 μ s
Power Dissipation	100 mW
Operating Temperature Range	-40 °C to 85 °C [-40 °F to 185 °F]
Dark Current	250 nA
Collector DC Current	30 mA
Collector-Emitter Breakdown Voltage	15 V
Emitter-Collector Breakdown Voltage	5 V
Collector-Emitter Saturation Voltage	1.1 V
Detector Color	White
IRED Anode Color	Red
IRED Cathode Color	Black
Detector Emitter Color	Green

Availability	Global
Product Name	Transmissive Sensor
Sensor Aperture	15,2 mm x 0,25 mm [0.60 in x 0.010 in]
Slot Width	3,18 mm [0.125 in]

Honeywell

HOA1887-013

HOA Series Transmissive Sensor, Darlington Output, Plastic Package

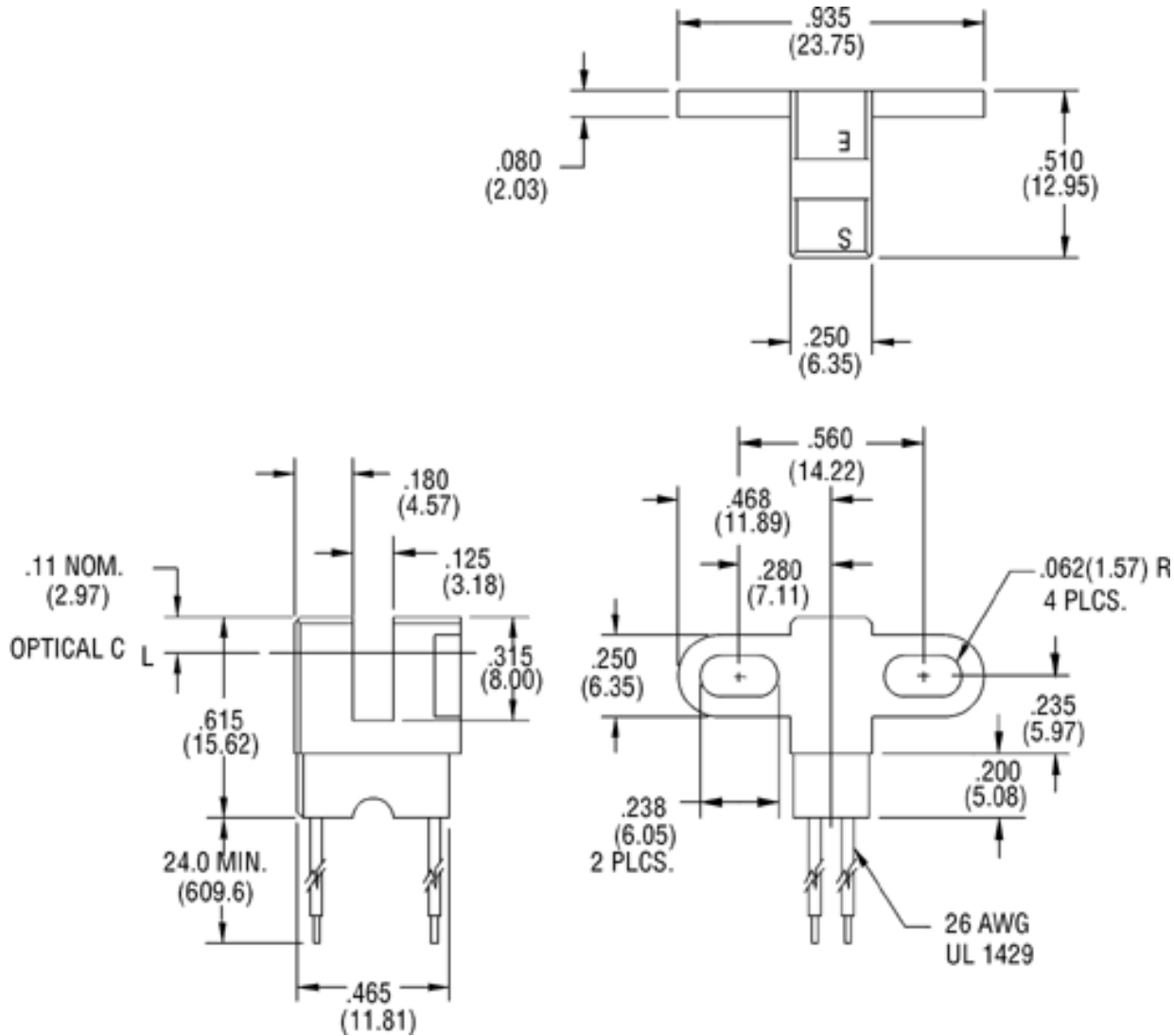

Honeywell

HOA1887-013

HOA Series Transmissive Sensor, Darlington Output, Plastic Package

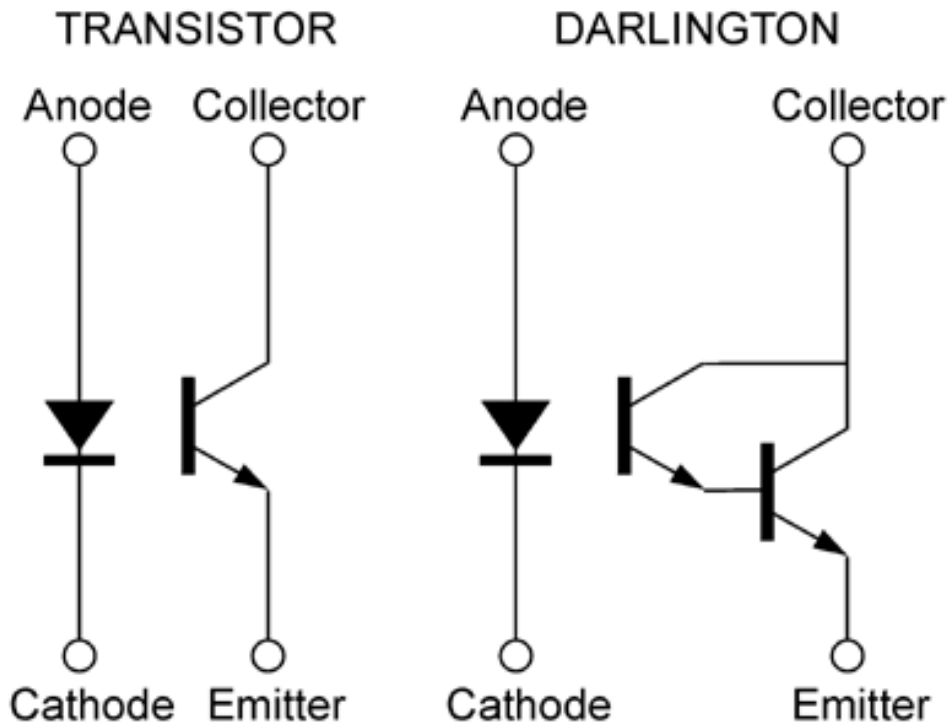

Honeywell

HOA1887-013

HOA Series Transmissive Sensor, Darlington Output, Plastic Package

⚠ WARNING

PERSONAL INJURY

DO NOT USE these products as safety or emergency stop devices, or in any other application where failure of the product could result in personal injury.

Failure to comply with these instructions could result in death or serious injury.

 **WARNING**

MISUSE OF DOCUMENTATION

- The information presented in this product sheet (or catalog) is for reference only. **DO NOT USE** this document as product installation information.
- Complete installation, operation and maintenance information is provided in the instructions supplied with each product.

Failure to comply with these instructions could result in death or serious injury.